

Exemplar
S-Class and
X-Class Servers

PCI Ultra SCSI Installation and Service Guide

Second Edition

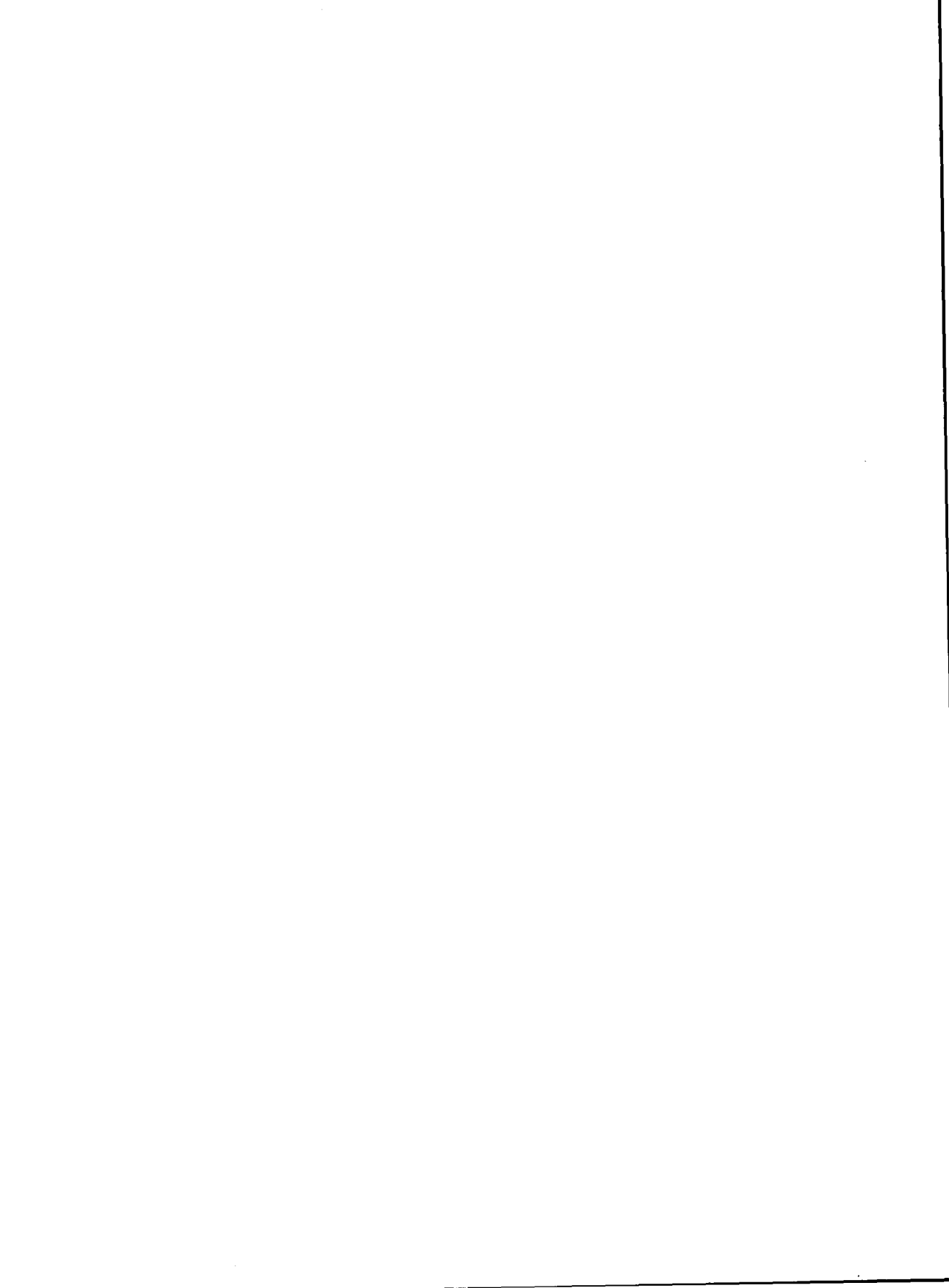

PCI Ultra SCSI

Installation and Service Guide

Exemplar S-Class and X-Class Servers

A4716-90024

Second Edition

July 1997

Hewlett-Packard Company
Convex Division
Richardson, Texas
United States of America

PCI Ultra SCSI Installation and Service Guide

Exemplar S-Class and X-Class Servers

A4716-90024

© Copyright Hewlett-Packard Company 1997. All Rights Reserved. Reproduction, adaptation, or translation without prior written permission is prohibited, except as allowed under the copyright laws.

Notice

The information contained in this document is subject to change without notice.

Hewlett-Packard makes no warranty of any kind with regard to this material, including, but not limited to, the implied warranties of merchantability and fitness for a particular purpose. Hewlett-Packard shall not be liable for errors contained herein or for incidental or consequential damages in connection with the furnishing, performance or use of this material.



This entire book is recyclable.

Printed in the United States of America

Revision Information for PCI Ultra SCSI Installation and Service Guide

Exemplar S-Class and X-Class Servers

Edition	Document No.	Description
Second	A4716-90024	Second release July 1997.
First	A4716-90011	Initial release January 1997.

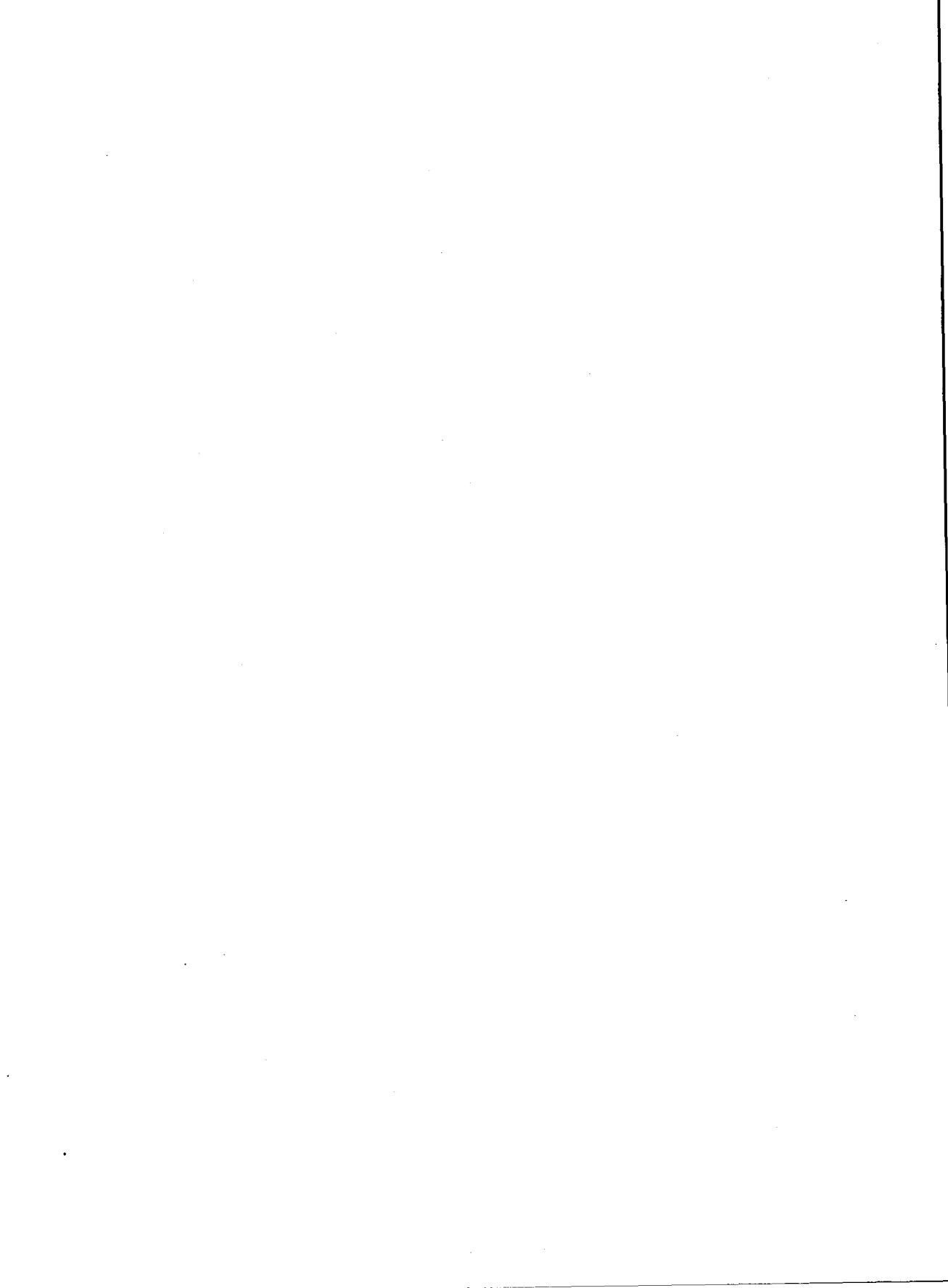

Contents

Preface	ix
Purpose and audience	ix
Notational conventions	ix
Notes and cautions	x
Associated documents	x
Ordering documents	xi
Technical assistance	xi
FCC notice	xi

1 Description and specifications	1
Description	1
Specifications	2

2 Unpacking and inspection	5
Inspection	5
Unpacking	5
Damage claims	5

3 Installation	7
Electrostatic discharge (ESD)	7
Antistatic packaging	7
Preparation	7
Preinstallation requirements	8
Overview of installation	8
Detailed installation instructions	9
Removing the EIOB	9
Installing the controller	15
Reinstalling the EIOB	16
Cabling	17
Completing the installation	18

4 Removal	19
Electrostatic discharge (ESD)	19
Antistatic packaging	19
Preparation	19

Tools required	19
Summary of removal procedure	20
Detailed removal instructions	21
Removing the EIOB	21
Removing the controller	27
Reinstalling the EIOB	28
Completing the removal procedure	29

5 Maintenance	31
Troubleshooting	31
Check the connection	31
Check the controller	31
Run diagnostics	31
Diagnostics	32
Overview	32
Class 3 EPIC PCI Access Test	32
Class 4 QLogic Mailbox Test	33
Running SCSI diagnostics	34
Upgrading controller firmware	36
Ultra SCSI runtime firmware	36
Ultra SCSI forth code	37
FRU list	38

Appendix A: PCI overview	39
PCI bus description	40
PCI terminology	41
PCI bus commands	42
PCI physical characteristics	43
PCI bus signals	44

Appendix B: SCSI overview	47
SCSI	47
SCSI terminology	47
SCSI bus phases	49
SCSI physical characteristics	50
Ultra SCSI	53

Appendix C: SCSI sense codes	55
---	-----------

Figures

Figure 1	EIOB locations	10
Figure 2	Removing side skins	11
Figure 3	Removing EMI panels	12
Figure 4	Unplugging the EIOB power cable	13
Figure 5	Removing the EIOB	14
Figure 6	Installing the controller	15
Figure 7	Reinstalling the EIOB	16
Figure 8	Connecting the SCSI cable	18
Figure 9	EIOB locations	22
Figure 10	Removing side skins	23
Figure 11	Removing EMI panels	24
Figure 12	Unplugging the EIOB power cable	25
Figure 13	Removing the EIOB	26
Figure 14	Removing the controller	27
Figure 15	Reinstalling the EIOB	28

Tables

Table 1	Specifications	2
Table 2	Shielded SCSI ribbon cables	3
Table 3	Differential SCSI cables	3
Table 4	EPIC and PCI slot numbering	35
Table 5	PCI Ultra SCSI controller FRU list	38
Table 6	PCI bus signals (required pins)	44
Table 7	PCI bus signals (optional pins)	45
Table 8	SCSI signals	51
Table 9	SCSI 68-pin differential cable pinout	52
Table 10	SCSI status codes	56
Table 11	SCSI sense keys	57
Table 12	SCSI Additional sense and Qualifier codes	58

Preface

Purpose and audience

The *PCI Ultra SCSI Installation and Service Guide* provides information for installing and maintaining a PCI Ultra SCSI controller in Hewlett-Packard Exemplar S-Class and X-Class Technical Servers. It is intended for anyone installing or servicing the PCI Ultra SCSI controller, including:

- Hewlett-Packard customers
- Hewlett-Packard Customer Engineers
- Hewlett-Packard CXD TAC

Notational conventions

This section discusses notational conventions used in this book.

Bold monospace

In command examples, text shown in **bold monospace** identifies user input that must be typed exactly as shown.

Monospace

In paragraph text, `monospace` identifies command names.

In command examples, `monospace` identifies command output, including error messages.

In command syntax diagrams, text shown in `monospace` must be typed exactly as shown.

Italic

In paragraph text, *italic* identifies new and important terms and titles of documents.

In command syntax diagrams, *italic* identifies variables that must be supplied by the user.

Notes and cautions

This document presents notes and cautions in the following formats.

Note

A Note highlights supplemental information.

Caution

A Caution highlights information necessary to avoid damage to the system.

Associated documents

For more information on Exemplar S-Class and X-Class Technical Servers and SCSI devices, you can order these books from Hewlett-Packard:

- *A4706A Installation Notice (A4706-90001)*. This document describes how installers are to provide physical hardware path information to customers for use during device integration on Exemplar S-Class and X-Class Servers.
- *Embedded Disk Installation and Service Guide: Exemplar X-Class and S-Class Servers (A4716-90009)*. This book provides information on installing and servicing the Embedded disk drive.
- *Barracuda 9 Installation and Service Guide: Exemplar S-Class and X-Class Servers (A4716-90008)*. This book provides information on installing and servicing the Barracuda 9 disk drive.
- *DDS-2 DAT Installation and Service Guide: Exemplar S-Class and X-Class Servers (A4716-90014)*. This book describes how to install and service the DDS-2 Digital Audio Tape (DAT) drive.
- *Digital Tape Autoloader Installation and Service Guide: Exemplar S-Class and X-Class Servers (A4716-90013)*. This book describes how to install the DLT4700 tape system mini-library.
- *Exemplar Site Preparation Guide: S-Class Servers (A4716-90005)*. This book provides technical information needed to prepare a site for the installation of an Exemplar S-Class Server.
- *Exemplar Installation Guide: S-Class Servers (A4716-90003)*. This book provides technical information and detailed procedures needed to install an Exemplar S-Class Server.
- *Exemplar Diagnostics Guide: S-Class and X-Class Servers (A4716-90002)*. This book provides a roadmap to all diagnostic programs. It also provides the user with definitive descriptions of the purpose of each test and defines minimum hardware configurations required for testing.

- *Exemplar Maintenance Guide: S-Class and X-Class Servers* (A4716-90004). This book is intended as a reference for system support engineers and manufacturing test personnel, as well as those customers who perform their own system maintenance.

Ordering documents

To order additional copies of this document or other documents listed in "Associated documents," send requests to:

Hewlett-Packard Company
Convex Division
Customer Service
P.O. Box 833851
Richardson TX 75083-3851 USA

Please include the order number (xxxxx-9xxxx) or the exact title of the document.

Technical assistance

If you have questions that are not answered in this book, contact the Hewlett-Packard Convex Technical Assistance Center (TAC) at the following locations:

Within the continental U.S., call 1 (800) 952-0379.

From Canada, call 1 (800) 345-2384.

All other locations, contact your local Hewlett-Packard office.

You can also use the `contact` utility, if you would like to report any problems you may have with the PCI Ultra SCSI controller or its associated documentation.

FCC notice

This equipment generates, uses, and can radiate radio frequency energy. If the equipment is not installed and used in strict accordance with the instruction manual, it may cause interference to radio communications.

This equipment has been tested and found to comply with limits for a Class A digital device, pursuant to Part 15 of the FCC Rules. These limits are designed to provide reasonable protection against harmful interference when equipment is operated in a commercial environment.

When this equipment is operated in a residential area, it is likely to cause interference. In this case, the interference must be corrected at the operator's expense.

Do not connect external equipment to the utility outlets in the Hewlett-Packard Exemplar S-Class and X-Class Technical Server. Unauthorized connection voids all agencies' emissions certification.

Description and specifications

1

Product type: **PCI Ultra SCSI controller**
Marketing number: **SCU2000**
Part number: **220-000058-201**

This chapter introduces the PCI Ultra SCSI controller and describes the components and characteristics of the board. Physical and environmental specifications are also included.

Description

The PCI Ultra SCSI controller is an intelligent, high-performance, direct memory access (DMA) bus master SCSI host adapter for Hewlett-Packard Exemplar S-Class and X-Class Technical Servers. The controller combines a powerful RISC processor, a SCSI executive processor, and a PCI Local Bus interface in a single chip solution. The controller supports bootable devices and can be used with hard drives, tape drives, and other SCSI devices. The controller is packaged as a single-slot, short card with a direct interface to the 32-bit PCI Local Bus.

The features of the PCI Ultra SCSI controller are listed below.

- Compliance with Intel PCI Local Bus Rev. 2.0 specification
- Compliance with ANSI X3.131-1994 SCSI-2 standard
- Compliance with ANSI X3T10/1071D SCSI-3 Fast-20 standard (Ultra SCSI)
- Supports asynchronous and synchronous transfer modes

- Synchronous SCSI data transfer rates:
 - Wide and Ultra SCSI (40 Mbytes/sec)
 - Ultra SCSI (20 Mbytes/sec)
 - Wide and Fast SCSI (20 Mbytes/sec)
 - Fast SCSI (10 Mbytes/sec)
 - Normal (5 Mbytes/sec)
- Supports differential mode
- Supports up to 15 SCSI devices
- Supports logical unit numbers (LUNs) 0-7
- Supports bus master DMA
- Single-chip, high performance SCSI RISC processor
- 68-pin, high density SCSI connector

Specifications

Table 1 shows the physical size, power requirements, and recommended operating environment for the PCI Ultra SCSI controller.

Table 1 Specifications

Characteristic	Value
Form factor	17.78 cm x 10.67 cm (7.0 in x 4.2 in)
Operating power	5 volts @ 1 ampere
Operating temperature	0 to 55 degrees C (32 to 158 degrees F)
Storage temperature	-20 to 70 degrees C (-4 to 158 degrees F)
Relative humidity	10% to 90% (noncondensing)
Storage humidity	5% to 95% (noncondensing)

The PCI Ultra SCSI controller supports differential SCSI connections only. Internal cables for interconnection with the Embedded Disk and DAT tape drive are provided in the system.

One shielded SCSI ribbon cable is provided with each controller for connection to a disk tray A or B port. The standard length of this cable is 13 inches, although 10-inch and 18-inch cables can be specified. Part numbers for the shielded SCSI ribbon cables are listed in Table 2.

For further information on connecting the controller to internal disk and tape devices, refer to the appropriate disk drive or tape drive product manual.

Table 2 Shielded SCSI ribbon cables

Description	Part number
10-inch SCSI shielded cable with back shell	612-000019-001
13-inch SCSI shielded cable with back shell	612-000019-002
18-inch SCSI shielded cable with back shell	612-000019-003

For connection to external SCSI devices, you must provide a differential SCSI cable. Table 3 shows the Hewlett-Packard differential SCSI cables and their part numbers.

Table 3 Differential SCSI cables

Description	Part number
2-meter SCSI shielded cable, HDM68-HDM68	604-680008-204 A4801-63005
5-meter SCSI shielded cable, HDM68-HDM68	604-680008-202 A4801-63003
10-meter SCSI shielded cable, HDM68-HDM68	604-680008-200 A4801-63001
20-meter SCSI shielded cable, HDM68-HDM68	604-680008-206

This chapter describes how to unpack and inspect the PCI Ultra SCSI controller from its shipping container and what to do if equipment is damaged.

Inspection

All shipping containers are designed to protect their components under normal shipping conditions. Carefully inspect each carton for signs of shipping damage *before* it is unpacked. If damage is found after visual inspection, document the damage with photographs and contact the transport carrier immediately.

Unpacking

Your bill of materials lists all equipment shipped from Hewlett-Packard. Use it as a checklist to ensure that all equipment has arrived.

Use the following procedure to unpack the shipping container:

- Step 1** Remove each item from its shipping container.
- Step 2** Inspect each item as it is unpacked for any signs of shipping damage.
- Step 3** If equipment damage is found, document the damage, and proceed to the next section.

Save all packing material until after operational checkout of the equipment. This enables equipment to be returned safely to Hewlett-Packard if required.

Damage claims

If the equipment is damaged, complete a damage claim form and give it to the shipping representative. Claim forms are normally obtained from the shipping representative.

This chapter describes how to install the PCI Ultra SCSI controller and connect it to an internal or external SCSI device.

Electrostatic discharge (ESD)

The PCI Ultra SCSI controller, as well as all other circuit boards, is highly susceptible to damage by electrostatic discharge during installation and routine maintenance procedures.

Caution

Do not handle circuit boards without a grounded wrist strap fastened to a good earth ground or to the system chassis.

Antistatic packaging

Circuit boards arrive in a specially designed bag that dissipates static electricity and serves as a shield against electrostatic fields while the board is in transit. Retain this bag and use it to store the circuit board if you remove it from the system for any reason.

The bag is not designed for use as a static dissipating mat. Do not use the antistatic bag for any other purpose than to enclose a circuit board. Holes in the bag render it useless as an antistatic measure. Therefore, it should always be completely closed and sealed when it contains a circuit board. Immediately discard and replace any bag that shows damage or wear.

Preparation

Prepare an ESD safe work surface large enough to accommodate the EIOB assembly.

Preinstallation requirements

Before beginning the installation, make sure there is an Exemplar I/O Board (EIOB) with an available PCI slot in the system. You can determine how many PCI slots are occupied and unoccupied by observing the Power On Self Test (POST) messages during the boot process. You can install the PCI Ultra SCSI controller in any available PCI slot, within any available EIOB.

If you intend to connect the PCI Ultra SCSI controller to an external SCSI device, you need to supply a differential SCSI cable that is long enough to reach the device. Part numbers for several different cable lengths are listed in the "Specifications" section in Chapter 1.

To install the PCI Ultra SCSI controller, you need a #2 Phillips screwdriver.

Overview of installation

Installing a PCI Ultra SCSI controller involves some minor disassembly of system assemblies. The following list provides a summary of the steps involved in the installation process.

Note

This list is intended for summary purposes only; detailed installation instructions are presented in the sections that follow.

- Step 1** Shut down the system.
- Step 2** Remove side skins and Electromagnetic Interference (EMI) panels.
- Step 3** Unplug EIOB power cable.
- Step 4** Disconnect all SCSI and network cables attached to controllers in this EIOB. Mark or chart the connections for easy connection later.
- Step 5** Remove EIOB.
- Step 6** Remove the bracket on top of the PCI card cage.
- Step 7** Install the controller.
- Step 8** Reinstall the bracket on top of the PCI card cage.
- Step 9** Reinstall EIOB.
- Step 10** Plug in the EIOB power cable.
- Step 11** Reattach all SCSI and network cables to the proper controller.
- Step 12** Attach the new SCSI cable. If it is an external cable, route the cable through the cable channel.
- Step 13** Reinstall EMI panels and side skins.

Step 14 Reboot the system.

Detailed installation instructions

The following sections provide detailed instructions on installing the PCI Ultra SCSI controller.

Removing the EIOB

To remove the EIOB, perform the following steps:

Step 1 Shut down the system with the `/etc/shutdown` command.

```
/etc/shutdown -h <time>
```

The *time* argument can be used to schedule a timed shutdown or the keyword "now" can be used to shut down the system immediately. Refer to the *SPP UX System Administrator's Guide* or the `shutdown` man page for more information on `/etc/shutdown`.

Step 2 Terminate power to the system by turning the keyswitch on the operator panel to the OFF position.

Caution

Do not remove the EIOB without first removing power to the system. Failure to remove power before removing the EIOB will damage electronic components on the board assembly.

Step 3 Select the EIOB where you intend to install the controller. The chassis can contain from one to four EIOBs, depending on your system configuration. You can install the PCI Ultra SCSI controller in any EIOB. However, the EIOB you are targeting for installation determines which side skin you need to remove in Step 4. Figure 1 shows the four possible locations of an EIOB in the chassis.

Figure 1 EIOB locations

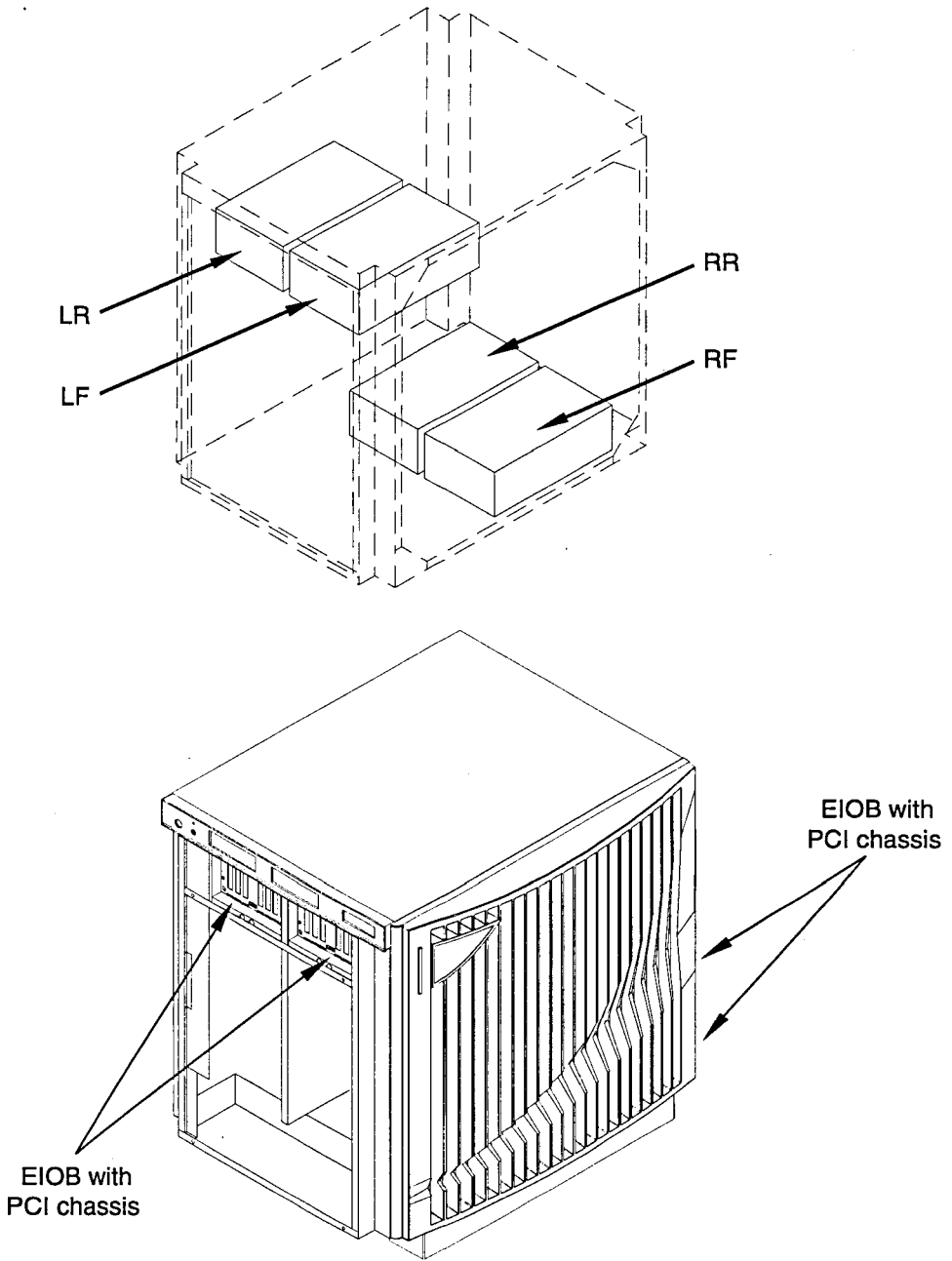

IOEX505
10/7/96

Step 4 Remove the left or right side cabinet skin by pulling from the top and bottom of the skin until it pops out. Each skin has a set of four catch pins that secure it to the chassis as shown in Figure 2.

Figure 2 Removing side skins

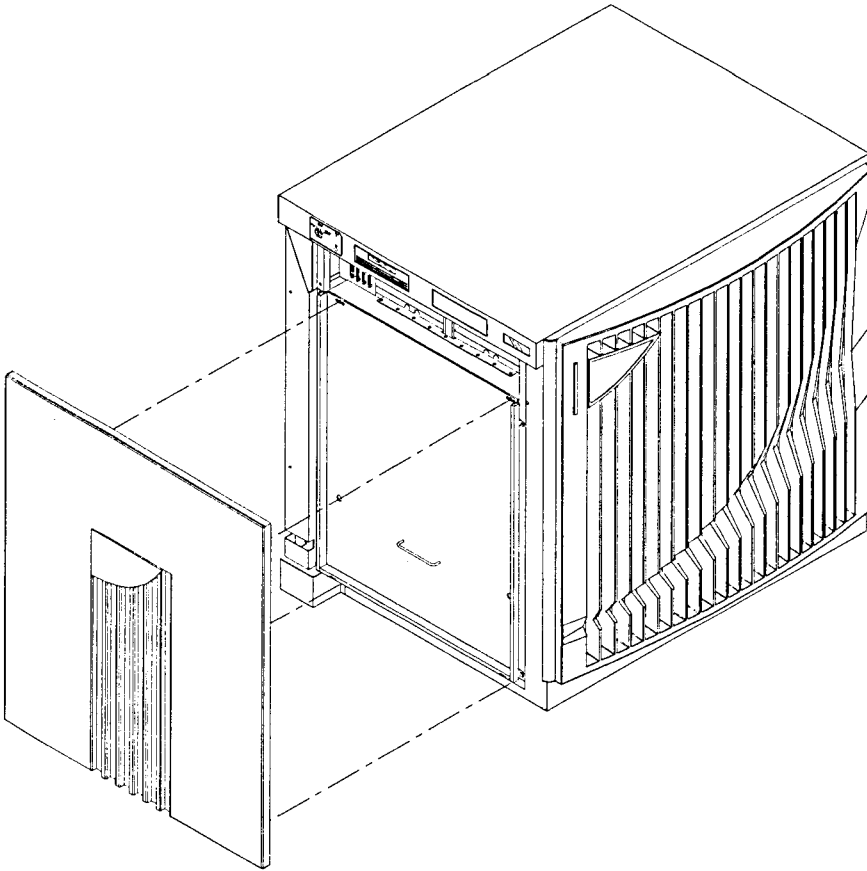

EXSM068
12/5/06

Step 5 Remove the EMI panel by removing the four screws that fasten the panel to the chassis as shown in Figure 3.

Figure 3 Removing EMI panels

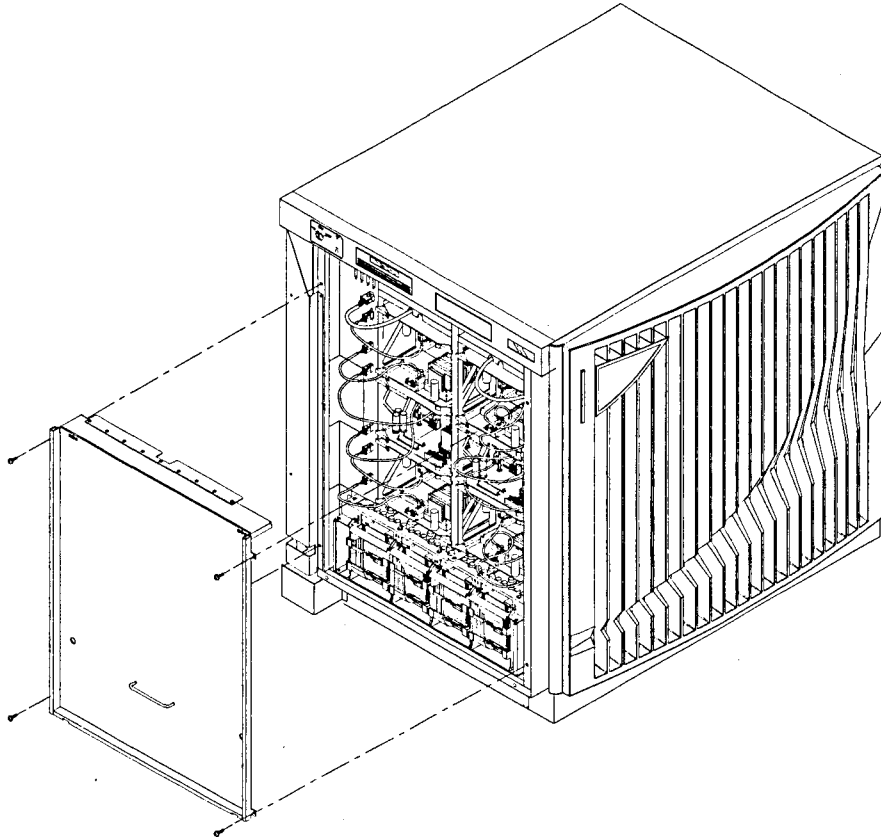

IOEXS031
12/5/96

Step 6 Unplug the power cable on the front of the target EIOB. The power connections are labeled on the chassis and are designated as follows:

IOLF I/O Left Front

IOLR I/O Left Rear

IORF I/O Right Front

IORR I/O Right Rear

Figure 4 shows the location of the IOLF and IOLR EIOB power connections. The IORF and IORR connectors are on the opposite side of the chassis near the bottom.

Figure 4 Unplugging the EIOB power cable

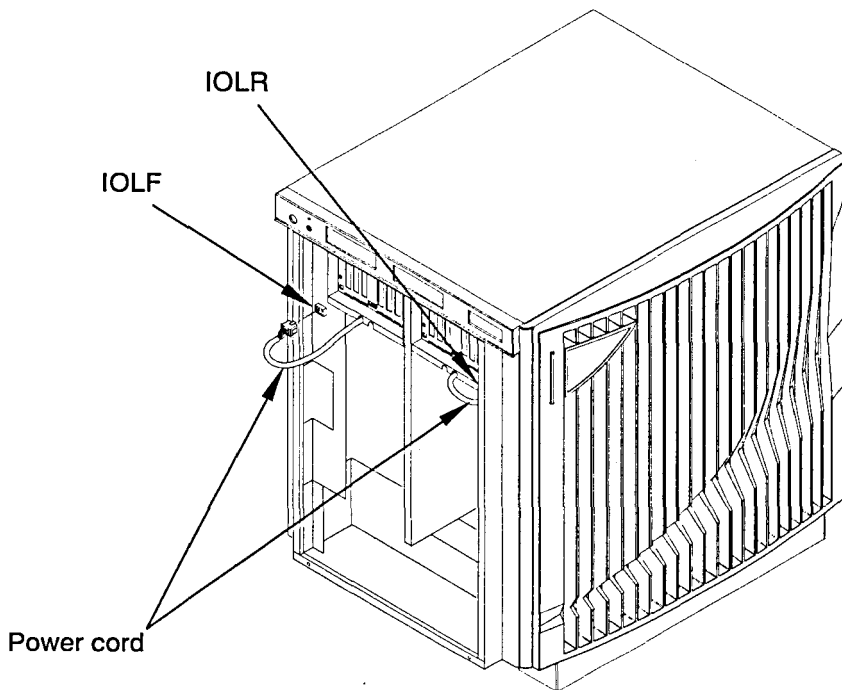

EIOP003
10/4/96

- Step 7** Disconnect all SCSI and network cables attached to controllers in this EIOB. Mark or chart the connections for easy connection later.
- Step 8** Remove the EIOB from the chassis by pulling the two extractor levers on the front of the EIOB toward you until the EIOB is unseated from the Exemplar Node Routing Board (ENRB). Continue sliding the EIOB all the way out, taking care to support it with one hand underneath (see Figure 5).
- Step 9** Place the EIOB on a level work surface that contains a grounded static dissipating mat.

Figure 5 Removing the EIOB

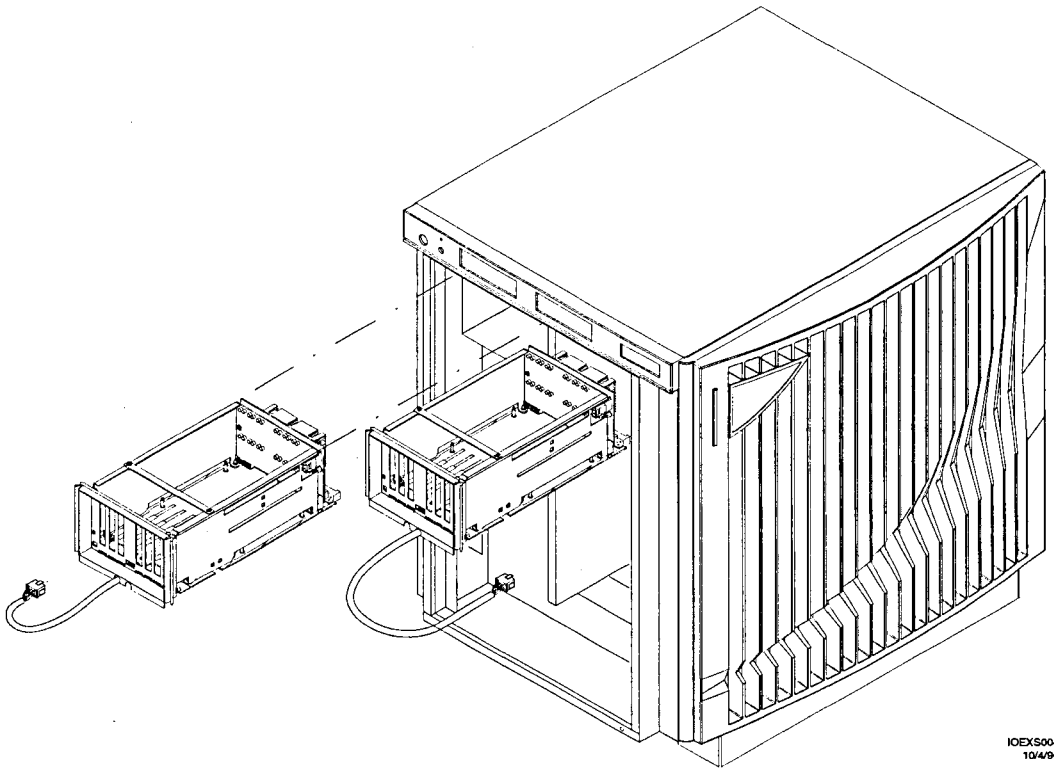

IOEX5004
10/4/96

Installing the controller

To install the PCI Ultra SCSI controller, perform the following steps:

- Step 1** Using a #2 Phillips screwdriver, remove the two screws that secure the bracket across the top of the PCI card cage. Refer to Figure 6 for the location of the bracket.

Figure 6 Installing the controller

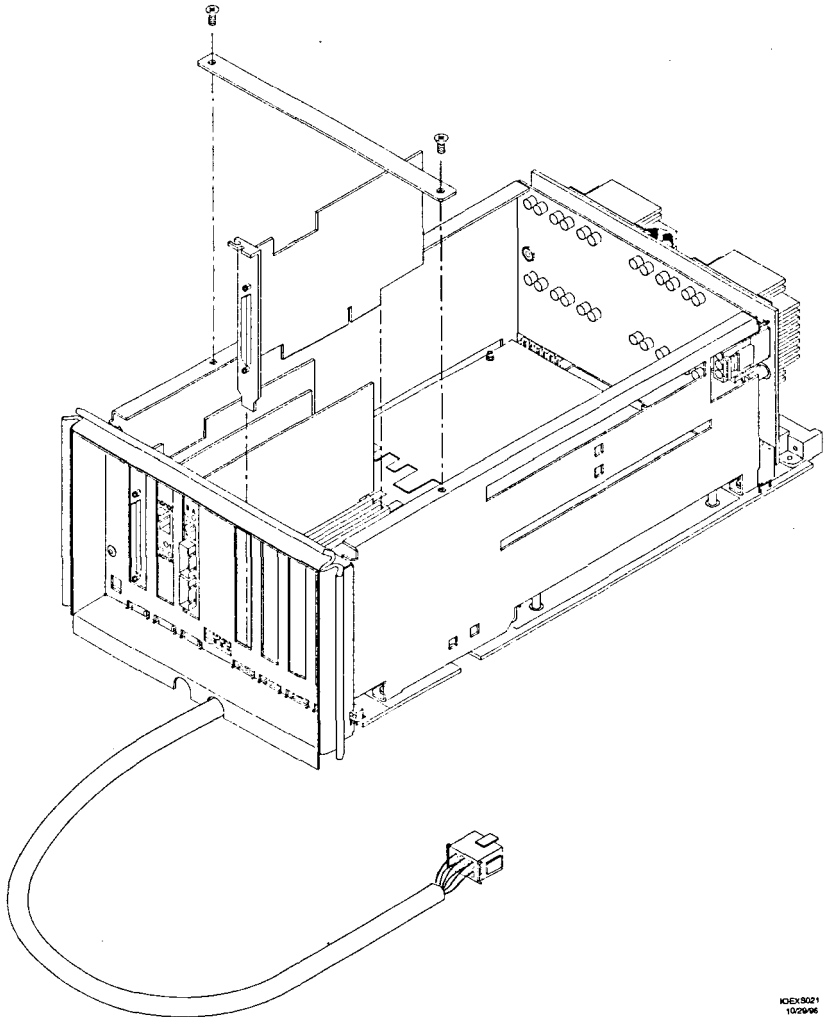

- Step 2** Select an available PCI slot and remove the PCI slot cover plate. Retain the screw for later use.
- Step 3** Insert the controller into the PCI slot as shown in Figure 6. Make sure the board is fully seated. Terminators are preinstalled and the SCSI ID is pre-set to ID 7.

- Step 4** Secure the controller faceplate to the PCI card cage using the screw from the PCI slot cover plate.
- Step 5** Reinstall the bracket on top of the PCI card cage.

Reinstalling the EIOB

To reinstall the EIOB, use the following procedure:

- Step 1** Reinstall the EIOB into the system chassis by lining up the EIOB card edges with the guide rails as shown in Figure 7. Continue sliding the EIOB into the chassis and secure it using the two extractor levers.

Figure 7 Reinstalling the EIOB

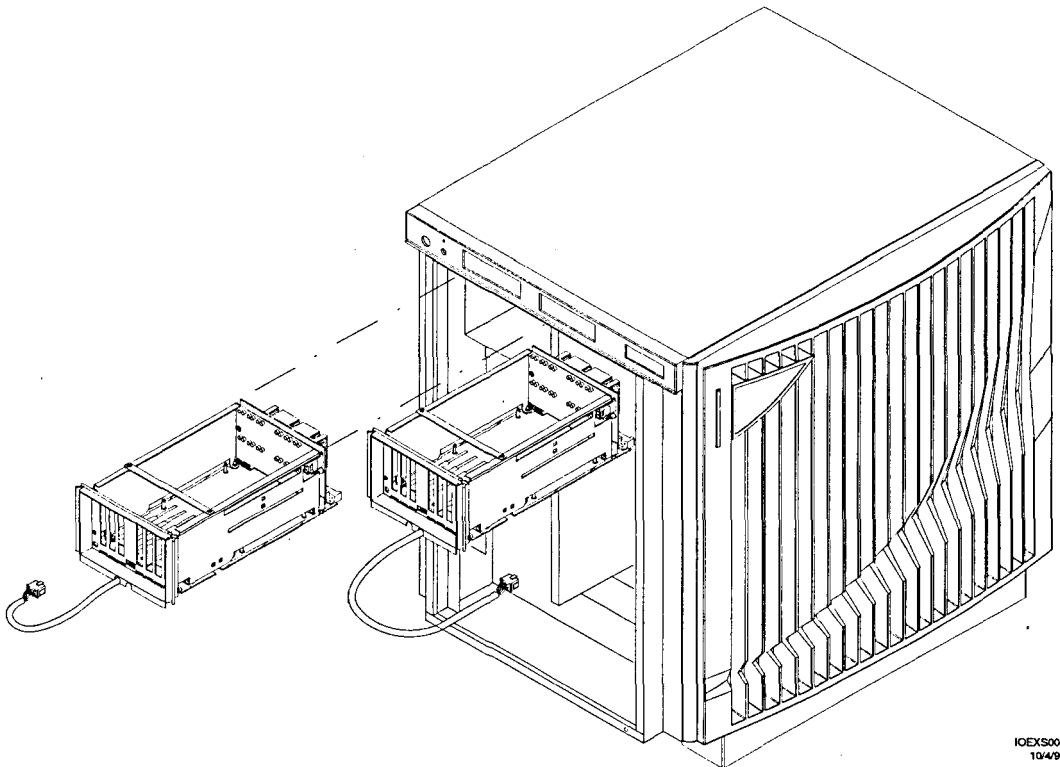

- Step 2** Reattach the power cable on the front of the EIOB (refer to Figure 4 for the location of the EIOB power connector).
- Step 3** Once you have installed the controller and EIOB, reattach any cables previously removed to their proper location.

Cabling

Once you have installed the controller and EIOB, you can attach the SCSI cable by following the steps below.

Note

A cable for connecting the PCI Ultra SCSI controller to a disk tray A or B port connector is supplied with the controller. Cable specifications are listed in Chapter 1.

- Step 1** Attach the SCSI cable to the connector on the controller as shown in Figure 8. The example in Figure 8 shows how to connect a shielded SCSI cable to a disk tray A or B port connector on the chassis. This cable is provided with the controller.

If you are connecting the controller to an external device, connect the external cable to the controller and route the cable through the cable channel at the rear edge of the server chassis. There are similar cable channels on the left and right rear edges of the chassis (refer to Figure 8). External SCSI cables can be ordered from Hewlett-Packard. A listing of available cables is provided in Chapter 1.

Figure 8 Connecting the SCSI cable

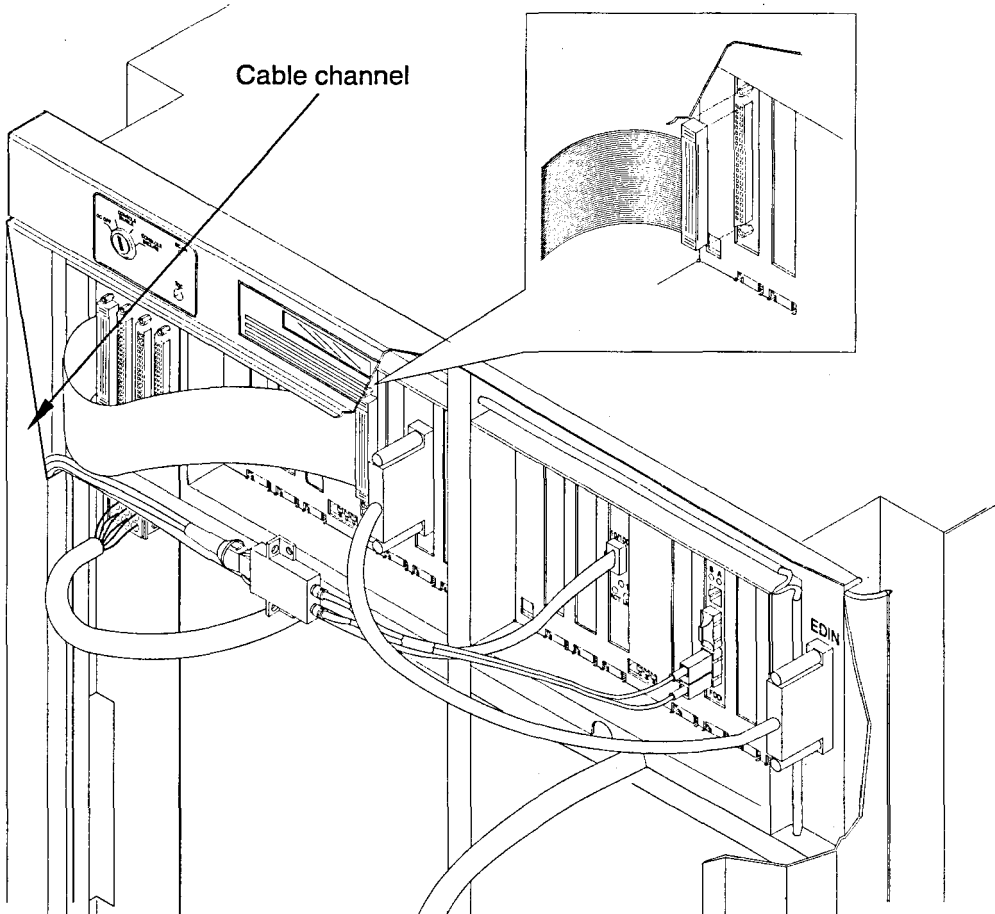

IOXS023
12/18/96

- Step 2** Complete the connection by attaching the other end of the cable to the SCSI device or appropriate disk tray port.

Completing the installation

To complete the installation, follow these steps:

- Step 1** Reinstall the EMI panels and side skins.
- Step 2** Restart the system by turning on the keyswitch on the operator panel.
- Step 3** Follow the instructions contained in the *A4706A Installation Notice* shipped with the controller.

Electrostatic discharge (ESD)

The PCI Ultra SCSI controller, as well as all other circuit boards, is highly susceptible to damage by electrostatic discharge during installation and routine maintenance procedures.

Caution

Do not handle circuit boards without a grounded wrist strap fastened to a good earth ground or to the system chassis.

Antistatic packaging

Circuit boards arrive in a specially designed bag that dissipates static electricity and serves as a shield against electrostatic fields while the board is in transit. Retain this bag and use it to store the circuit board if you remove it from the system for any reason.

The bag is not designed for use as a static dissipating mat. Do not use the antistatic bag for any other purpose than to enclose a circuit board. Holes in the bag render it useless as an antistatic measure. Therefore, it should always be completely closed and sealed when it contains a circuit board. Immediately discard and replace any bag that shows damage or wear.

Preparation

Prepare an ESD safe work surface large enough to accommodate the EIOB assembly.

Tools required

To remove the PCI Ultra SCSI controller, you need a #2 Phillips screwdriver.

Summary of removal procedure

Removing a PCI Ultra SCSI controller involves some minor disassembly of system assemblies. The following list provides a summary of the steps involved in the removal process.

Note

This list is intended for summary purposes only; detailed instructions for removal are presented in the sections that follow.

- Step 1** Shut down the system.
- Step 2** Remove side skins and Electromagnetic Interference (EMI) panels.
- Step 3** Unplug EIOB power cable.
- Step 4** Disconnect all SCSI and network cables attached to controllers in this EIOB. Mark or chart the connections for easy connection later.
- Step 5** Remove EIOB.
- Step 6** Remove the bracket on top of the PCI card cage.
- Step 7** Remove the controller.
- Step 8** If you are replacing the controller, install the new controller in an available PCI slot.
- Step 9** Reinstall the bracket on top of the PCI card cage.
- Step 10** Reinstall EIOB.
- Step 11** Plug in the EIOB power cable.
- Step 12** Reattach all SCSI and network cables to the proper controller.
- Step 13** If you installed a new controller, attach the SCSI cable and route the cable through the cable channel if necessary.
- Step 14** Reinstall EMI panels and side skins.
- Step 15** Reboot system.

Detailed removal instructions

The following sections provide detailed instructions on removing the PCI Ultra SCSI controller.

Removing the EIOB

To remove the EIOB, perform the following steps:

- Step 1** Shut down the system with the `/etc/shutdown` command.
- ```
/etc/shutdown -h <time>
```
- The *time* argument can be used to schedule a timed shutdown or the keyword "now" can be used to shut down the system immediately. Refer to the *SPP UX System Administrator's Guide* or the `shutdown` man page for more information on `/etc/shutdown`.
- Step 2** Terminate power to the system by turning the keyswitch on the operator panel to the OFF position.

---

## Caution

---

**Do not remove the EIOB without first removing power to the system. Failure to remove power before removing the EIOB will damage electronic components on the board assembly.**

- Step 3** Select the EIOB that contains the controller you intend to remove. The chassis can contain from one to four EIOBs, depending on your system configuration. The EIOB you are targeting determines which side skin you need to remove in Step 4. Figure 9 shows the four possible EIOB locations in the chassis.

Figure 9 EIOB locations

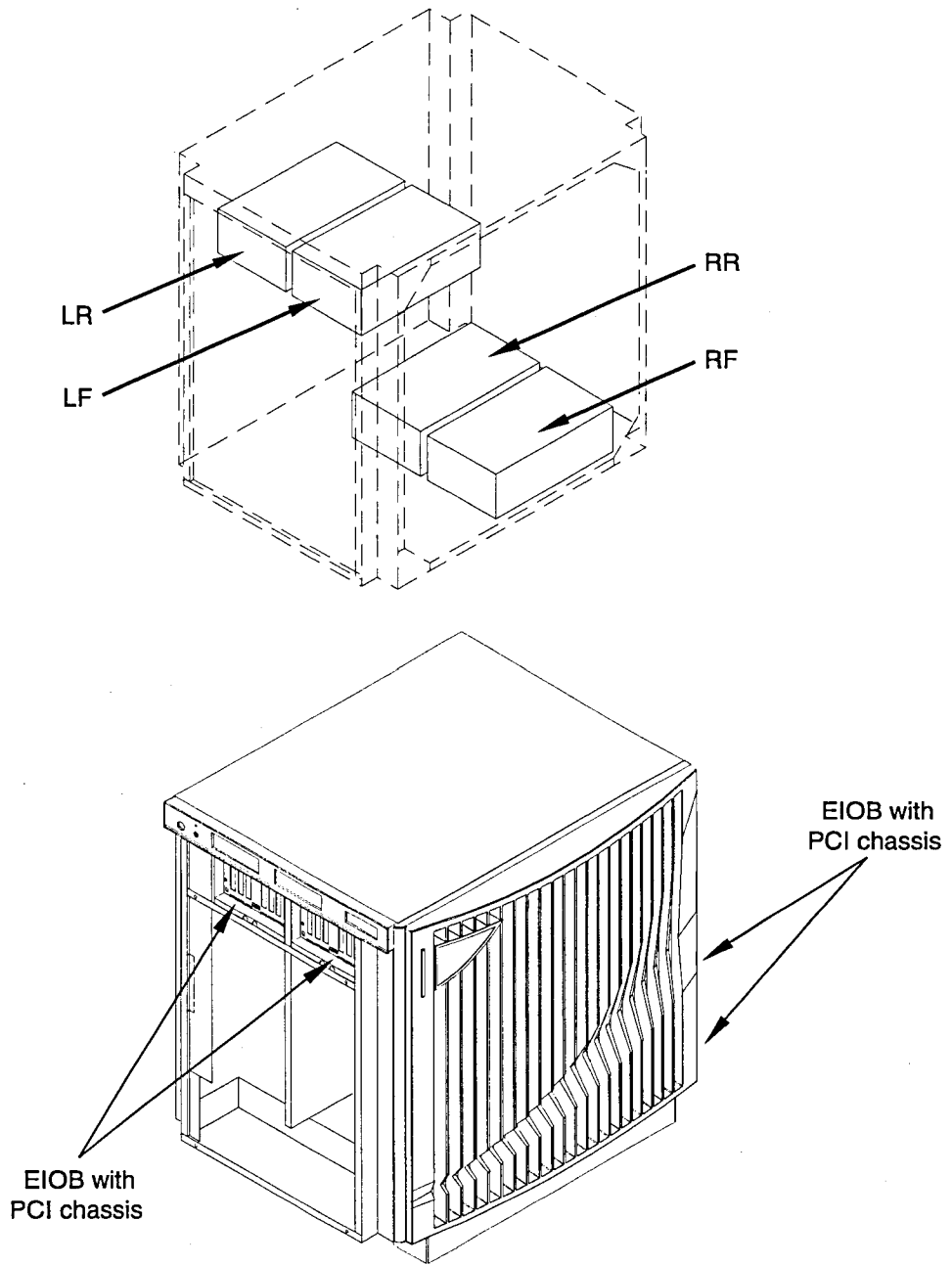

IOEX5005  
10/7/95

**Step 4** Remove the left or right side cabinet skin by pulling from the top and bottom of the skin until it pops out. Each skin has a set of four catch pins that secure it to the chassis as shown in Figure 10.

**Figure 10** Removing side skins

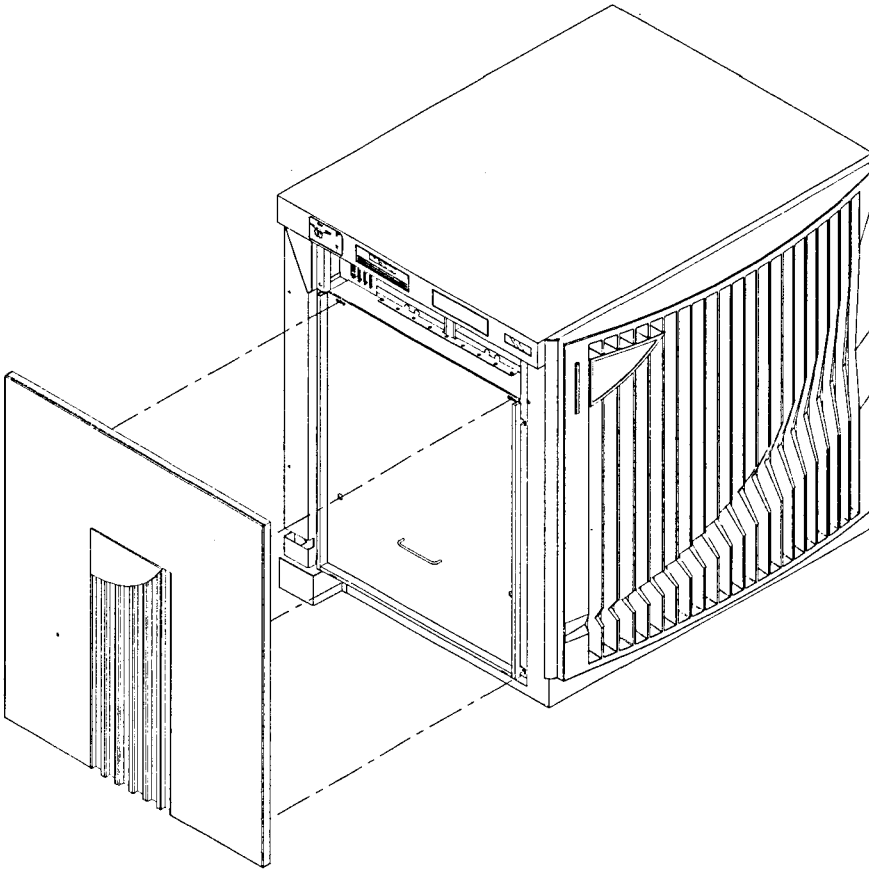

EXSM068  
12/5/96

**Step 5** Remove the EMI panel by removing the four screws that fasten the panel to the chassis as shown in Figure 11.

**Figure 11** Removing EMI panels

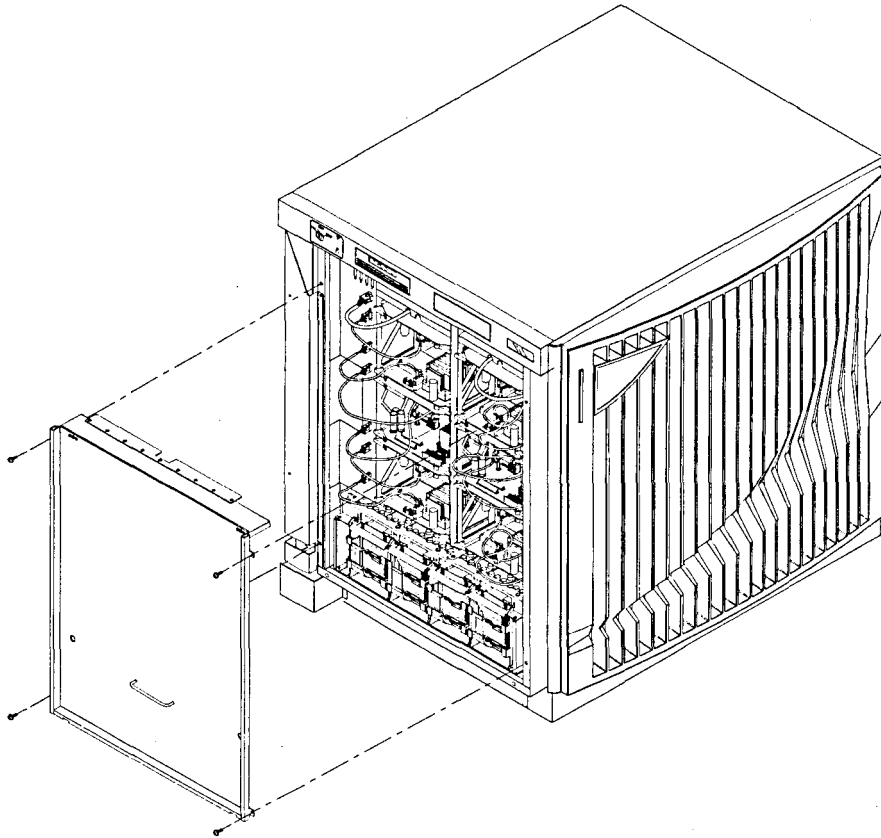

IOXS031  
12/5/96

**Step 6** Unplug the power cable on the front of the target EIOB. The power connections are labeled on the chassis and are designated as follows:

IOLF I/O Left Front

IOLR I/O Left Rear

IORF I/O Right Front

IORR I/O Right Rear

Figure 12 shows the location of the IOLF and IOLR EIOB power connections. The IORF and IORR connectors are on the opposite side of the chassis near the bottom.

**Figure 12** Unplugging the EIOB power cable

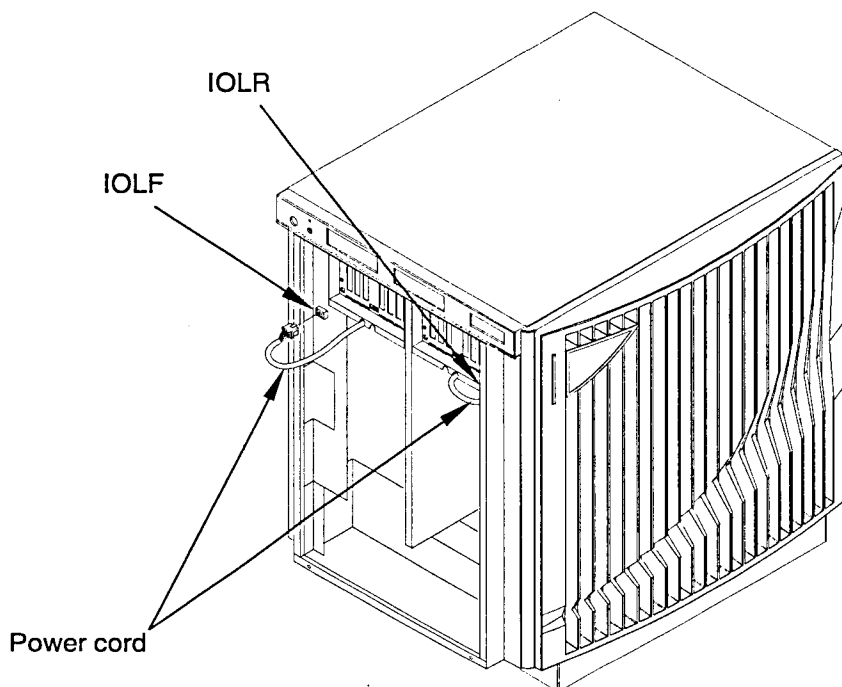

EIOP003  
10/4/96

- Step 7** Disconnect all SCSI and network cables attached to controllers in this EIOB. Mark or chart the connections for easy connection later.
- Step 8** Remove the EIOB from the chassis by pulling the two extractor levers on the front of the EIOB toward you until the EIOB is unseated from the Exemplar Node Routing Board (ENRB). Continue sliding the EIOB all the way out, taking care to support it with one hand underneath (see Figure 13).
- Step 9** Place the EIOB on a static free, level work surface.

Figure 13 Removing the EIOB

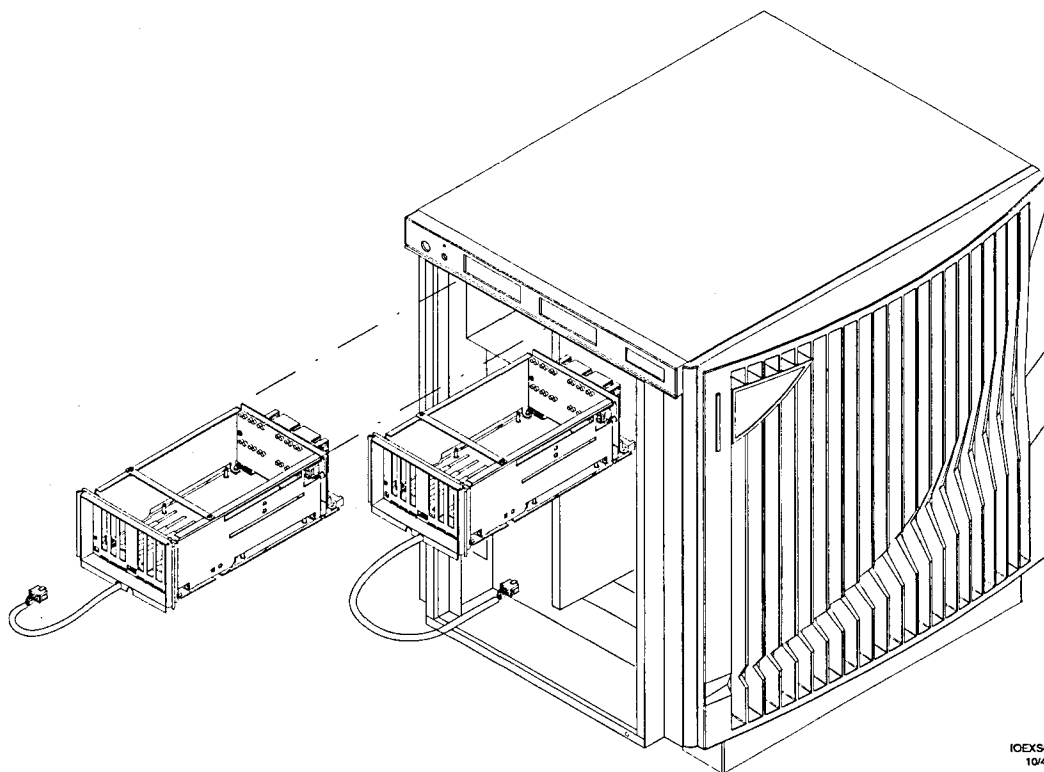

IOEXS004  
10/4/96

---

## Removing the controller

To remove a PCI Ultra SCSI controller, perform the following steps:

- Step 1** Using a #2 Phillips screwdriver, remove the two screws that secure the bracket across the top of the PCI card cage. Refer to Figure 14 for the location of the bracket.

Figure 14 Removing the controller

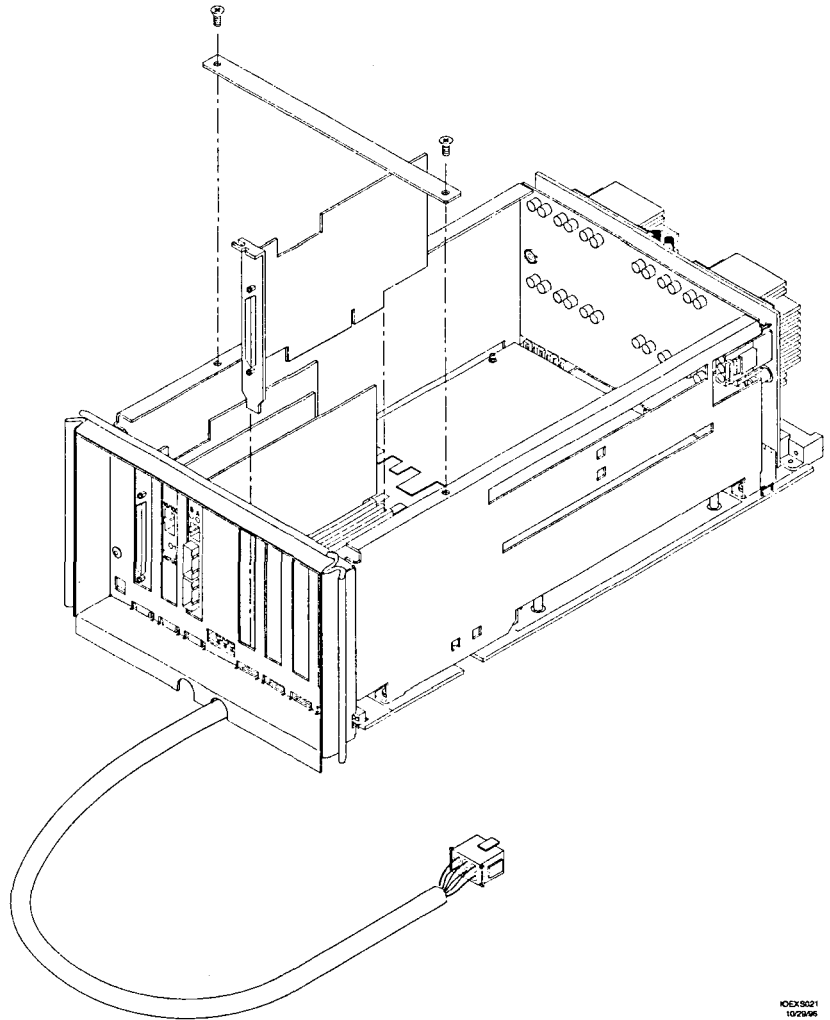

- Step 2** Remove the screw on the faceplate of the PCI Ultra SCSI controller. Retain the screw for later use.
- Step 3** Remove the controller by grabbing the edges of the board and pulling upward until the controller is free from the PCI connector.

10EX8021  
10/2006

- Step 4** If you are replacing the controller, install the new controller at this time. If you are not replacing the controller, install a PCI slot cover plate over the space where the controller was removed. Secure the cover with the screw you removed in Step 2.
- Step 5** Reinstall the bracket on top of the PCI card cage.

---

## Reinstalling the EIOB

To reinstall the EIOB, use the following procedure:

- Step 1** Reinstall the EIOB into the system chassis by lining up the EIOB card edges with the guide rails as shown in Figure 15. Continue sliding the EIOB into the chassis and secure it using the two extractor levers.

**Figure 15** Reinstalling the EIOB

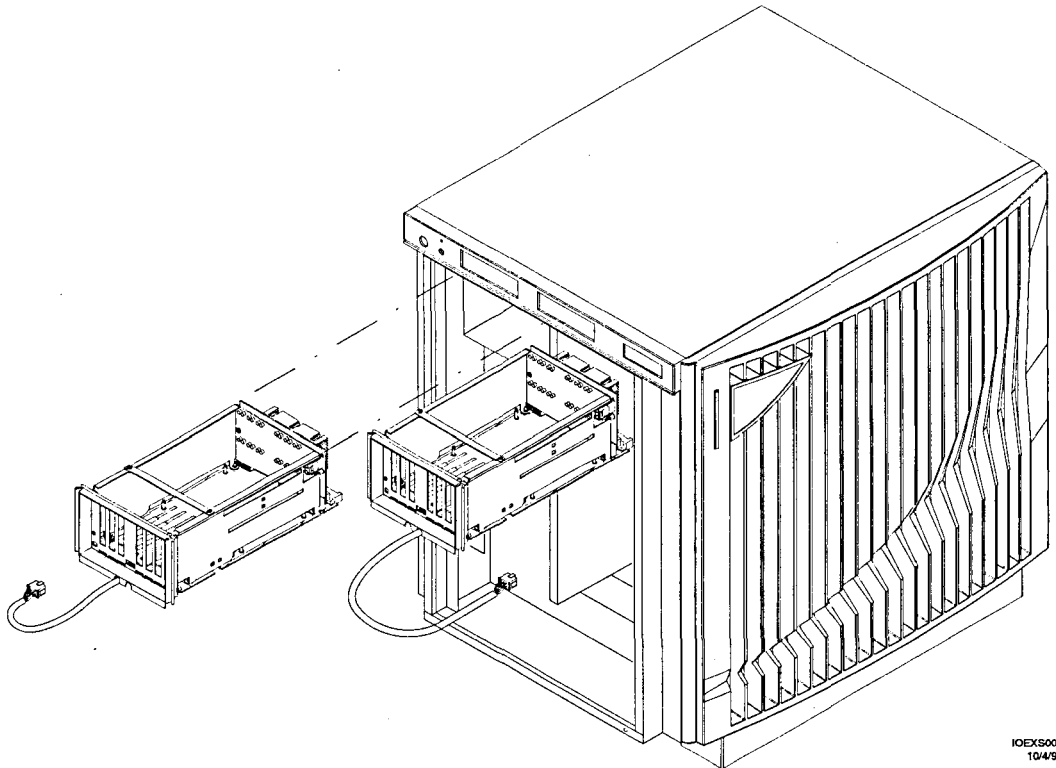

IOEXS004  
10/4/96

- Step 2** Reattach the power cable on the front of the EIOB (refer to Figure 12 for the location of the EIOB power connector).
- Step 3** Once you have installed the EIOB, reattach any cables previously removed to their proper location.

---

## Completing the removal procedure

To complete the removal procedure, follow these steps:

- Step 1** Reinstall the EMI panels and side skins.
- Step 2** Restart the system by turning on the keyswitch on the operator panel.



This chapter provides information on troubleshooting, testing, and diagnosing problems with the PCI Ultra SCSI controller.

---

## Troubleshooting

The PCI Ultra SCSI controller is a single Field Replaceable Unit (FRU) and does not contain any field-serviceable parts. Troubleshooting procedures described in this section are limited to verifying that the controller is operational and a valid connection is established. A listing of SCSI sense codes reported in SCSI error messages is provided in Appendix C, as an aid in troubleshooting.

---

### Check the connection

Check to see if the correct cable is used and that the cable is connected and operating properly.

---

### Check the controller

Perform a visible inspection to make sure the controller is seated properly in the PCI bus slot. If necessary, power down the system, reseal the controller, and restart the system.

---

### Run diagnostics

If a visual inspection of the controller and cable does not reveal any problems, or if an action taken as a result of the inspection does not produce a working controller, you may want to run diagnostics to determine whether the controller can communicate and respond to PCI bus instructions. Diagnostics are described in the next section.

If diagnostics determine that the controller is defective, you need to replace it. Contact your local Hewlett-Packard customer representative or call the Technical Assistance Center at one of the following locations for information on replacing and repairing the controller:

- Within the continental U.S., call 1 (800) 952-0379.
- From Canada, call 1 (800) 345-2384.
- All others, contact your local Hewlett-Packard sales office.

---

## Diagnostics

If you are experiencing problems with your SCSI devices and suspect that the controller may be malfunctioning, you can perform a diagnostic check of the controller to determine whether it is operational. To run these diagnostics, you need to reboot the system to the system Test Controller in standalone mode and run the `cxtest` utility.

---

### Overview

The `cxtest` utility provides a graphical interface to the diagnostic environment. Diagnostic tests for the PCI Ultra SCSI controller are located in the `io3000` suite of diagnostics. The `io3000` diagnostic suite is organized into *classes*. Within each class there are one or more diagnostic *subtests*. The PCI SCSI controller diagnostic classes are called Class 3 - EPIC PCI Access Test and Class 4 - QLogic Mailbox Test.

#### Class 3 EPIC PCI Access Test

The Class 3 EPIC PCI Access diagnostic consists of two subtests:

- 300 EPIC Configuration Space Test
- 305 EPIC I/O and Memory Space Test

The EPIC Configuration Space Test determines whether the EPIC (Exemplar PCI Interface Chip) can talk to the PCI Ultra SCSI controller by using PCI config space cycles to read the vendor ID and device ID of the controller. If this test fails, it indicates that the EPIC is unable to talk to the controller.

The EPIC I/O and Memory Space Test then maps the controller into I/O and memory space by setting the I/O Base Address Register and Memory Base Address Register on the controller. If this test fails, it indicates that the EPIC can communicate with the controller, but it is unable to read and write the Control and Status Registers (CSRs) via I/O and/or memory cycles. Instructions for

running these tests are provided in the section, "Running SCSI diagnostics."

These two diagnostic subtests are designed to test whether the controller can be recognized and initialized by the PCI config, I/O, and memory cycles. They do not test the full functionality of the board. To test the operation of specific disk and tape drives connected to a PCI Ultra SCSI controller, refer to the manual for that individual disk or tape drive and to the *Exemplar Diagnostics Guide*.

#### **Class 4 QLogic Mailbox Test**

The Class 4 QLogic Mailbox diagnostic consists of two subtests:

- 400 QLogic Mailbox Test
- 405 QLogic Firmware Download and Test

The QLogic Mailbox Test verifies the QLogic mailbox interface by using the controller's mailbox loopback mechanism to write data to and read data from the controller CSRs. The mailbox is a command interface to the controller that allows an opcode and associated arguments to be sent to the controller via controller CSR write commands. Responses to these commands are placed into controller CSR space and can be subsequently read by the host once the command finishes.

The QLogic Firmware Download and Test loads the controller firmware from system flash memory on the Exemplar CU Board (ECUB) into a specified location in the controller's SRAM. The download is accomplished through the `load ram mailbox` command. Once the code is loaded, a `verify checksum mailbox` command is issued to verify the code, followed by an `execute from ram mailbox` command to run the newly loaded code.

The firmware revision is then checked with the `about firmware mailbox` command. Options have been provided to use a version of SCSI firmware other than the released version (refer to the section "Upgrading controller firmware" for details). This subtest is the first subtest to require an EPIC to transfer data from coherent memory to the controller.

For a complete description of `ctest` and the Test Controller diagnostic environment, refer to the *Exemplar Diagnostics Guide*. For specific information on the io3000 diagnostics suite, refer to the io3000 man page.

---

## Running SCSI diagnostics

To run the PCI Ultra SCSI controller diagnostics, perform the following steps:

- Step 1** From the teststation, reboot the system so that it boots the Test Controller in standalone mode instead of OBP. For specific instructions on booting the system to the Test Controller and operating in the diagnostic environment, refer to the *Exemplar Diagnostics Guide*.
- Step 2** Execute `cxtest` :  
`/spp/bin/cxtest -d`
- Step 3** In the Tests menu, select `io3000` to display the `io3000 Class Menu` dialog.
- Step 4** In the Class Menu dialog, select `Class 3 - EPIC PCI Access Test` and `Class 4 - QLogic Mailbox Test`. When you select a class, you select all the subtests within that class. You can, however, select specific subtests within a class by selecting the subtest button.

**Step 5** From the Class Menu dialog, select the Parameters button to specify the parameters of the test(s). The parameters are as follows:

*Epic*

This parameter identifies the EPIC where the Ultra SCSI controller resides. Valid entries can be any of the values from the first column in Table 4.

**Table 4** EPIC and PCI slot numbering

| Parameter to enter | EPIC      | PCI slots | Description                  |
|--------------------|-----------|-----------|------------------------------|
| IOLF_B             | 0 (rear)  | 0, 1, 2   | Left front EIOB, rear EPIC   |
| IOLF_A             | 4 (front) | 0, 1, 2   | Left front EIOB, front EPIC  |
| IOLR_B             | 1 (rear)  | 0, 1, 2   | Left rear EIOB, rear EPIC    |
| IOLR_A             | 5 (front) | 0, 1, 2   | Left rear EIOB, front EPIC   |
| IORF_B             | 3 (rear)  | 0, 1, 2   | Right front EIOB, rear EPIC  |
| IORF_A             | 7 (front) | 0, 1, 2   | Right front EIOB, front EPIC |
| IORR_B             | 2 (rear)  | 0, 1, 2   | Right rear EIOB, rear EPIC   |
| IORR_A             | 6 (front) | 0, 1, 2   | Right rear EIOB, front EPIC  |

*Controller*

This parameter identifies the PCI slot number of the controller. The value can be 0, 1, 2, or 0xf. An entry of 0xf indicates that this device specification is unused.

*Target device number*

This is the target device number of the device (SCSI ID), expressed in hexadecimal. For diagnostic Classes 3 and 4, this field is unused.

*Logical Unit Number*

This is the logical unit number of the device, expressed in hexadecimal. For diagnostic Classes 3 and 4, this field is unused.

**Step 6** Click the Done button to close the Class Menu dialog.

**Step 7** Select Go from the `cxtest` Command menu to execute the tests. You will see the following in the Console window:

Execution Starting.

.....

- Step 8** When the test terminates (successfully or unsuccessfully), the console window will display the following message:  
Execution Completed.

The results of the test will be displayed in the `cxtest` window.

If the test fails, an error message will be displayed. For a complete description of error messages, refer to the `io3000` man page and the *Exemplar Diagnostics Guide*.

---

## Upgrading controller firmware

The PCI Ultra SCSI controller contains two sets of firmware: runtime firmware and forth code that is required for the controller to be in the boot path.

---

### Ultra SCSI runtime firmware

To use a different version of the runtime firmware (other than the released version), follow these procedures:

- Step 1** Load the new firmware onto the teststation. Released firmware is stored in the `/spp/firmware` directory on the teststation.

---

## Caution

**Do not overwrite the original released firmware filename when storing custom firmware on the teststation.**

- Step 2** Load the new firmware into core logic flash on the system using the `obp fwcp` command. The syntax for `fwcp` is:

```
fwcp <test_station_ip_address>:<firmware_path> <tag>
```

where:

*test\_station\_ip\_address*

is the IP address of the teststation

*firmware\_path*

is the absolute path to the firmware file

*tag*

identifies the address in flash for OBP

For example:

```
[0:8] ok fwcp 15.99.111.99:/spp/firmware/myuscsi.fw USCSI
```

**Step 3** Run the `ctest` utility and load the io3000 diagnostics suite. Refer to the section “Running SCSI diagnostics” in this chapter for instructions on running `ctest`.

**Step 4** In io3000, set the custom SCSI firmware enable option and the custom SCSI firmware length. Use the `ll` command to obtain the size of the firmware file for the custom SCSI firmware length option. For example:

```
ll /spp/firmware/myuscsi.fw
-r--r--r-- 1 sppuser sppuser 21826 Nov 1 17:37 /spp/firmware/myuscsi.fw
```

The length option must be specified in half-words (16 bit quantity) and in hexadecimal notation. Therefore, you must divide the firmware file size by 2 and convert it to hexadecimal. Once you decide to operate the PCI Ultra SCSI controller with nonreleased firmware, you must always set the custom SCSI firmware enable and custom SCSI firmware length options when running SCSI diagnostics.

---

### Ultra SCSI forth code

To upgrade the controller’s forth code, use the following procedure:

**Step 1** Load the new firmware onto the teststation. Released firmware is stored in the `/spp/firmware` directory on the teststation.

---

## Caution

---

**Do not overwrite the original released firmware filename when storing custom firmware on the teststation.**

**Step 2** Load the new firmware into core logic flash on the system using the `obp fwcp` command. The syntax for `fwcp` is:

```
fwcp <test_station_ip_address>:<firmware_path> <tag>
where:
```

*test\_station\_ip\_address*

is the IP address of the teststation

*firmware\_path*

is the absolute path to the firmware file

*tag*

identifies the address in flash for OBP

For example:

```
[0:8] ok fwcp 15.99.111.99:/spp/firmware/myfth_code.fw PAD
```

- Step 3** Run the `ctest` utility and load the io3000 diagnostics suite. Refer to the section "Running SCSI diagnostics" in this chapter for instructions on running `ctest`.
- Step 4** In io3000, select Class 12 - Utility Functions and execute both subtests (SCSI forth code download and SCSI forth code verify). The forth code will be loaded and verified.

---

## FRU list

The following table lists the Hewlett-Packard part numbers for the PCI Ultra SCSI controller Field Replaceable Units (FRUs).

Table 5 PCI Ultra SCSI controller FRU list

| Description                                 | Part number    |
|---------------------------------------------|----------------|
| PCI Ultra SCSI controller                   | 220-000058-201 |
| 10-inch SCSI shielded cable with back shell | 612-000019-001 |
| 13-inch SCSI shielded cable with back shell | 612-000019-002 |
| 18-inch SCSI shielded cable with back shell | 612-000019-003 |

This appendix provides a brief introduction and overview to the PCI Local Bus. For a complete description of the bus, refer to the PCI Local Bus Specification, Revision 2.1. You can obtain a copy of the specification by contacting the PCI Special Interest Group:

PCI Special Interest Group  
P.O. Box 14070  
Portland, OR  
USA 97214

In the US call (800) 433-5177  
International call 1 (503) 797-4207  
Fax 1 (503) 234-6762

---

## PCI bus description

The Peripheral Component Interconnect (PCI) Local Bus is an industry standard, high-performance, 32-bit or 64-bit synchronous bus with multiplexed address and data lines. It is specified for data rates up to 132 MBytes/second using a 32-bit wide data path and 264 MBytes/second using a 64-bit data path. The bus provides a complete set of multiprocessing and high performance features, including:

- Multiple bus master
- Overlapped (hidden) bus arbitration
- Burst-mode data transfers
- Multiprocessing support (resource locking)
- Cache coherency support
- 64-bit addressing capability
- Interrupts
- Configuration space

The PCI Local Bus is intended to be an interconnect mechanism between highly integrated peripheral controller components, peripheral expansion cards, and processor/memory systems. The processor and memory are connected through a *bridge* that provides a low latency path by which a processor can access PCI devices mapped anywhere in memory or I/O address space. It also provides a high bandwidth path allowing a PCI master direct access to main memory. The bridge may also include functions such as data buffering and posting, and PCI central functions such as arbitration.

Exemplar S-Class and X-Class Technical Servers support the 32-bit PCI Local Bus. There can be from one to eight independent busses in a node, with three expansion slots in each bus.

---

## PCI terminology

The PCI specification defines several terms and acronyms. Some of these terms are described below.

### *PCI Local Bus*

The Peripheral Component Interconnect bus. PCI was originally developed by Intel as a local bus for high-end PC systems. It now falls under the jurisdiction of the PCI Special Interest Group (PCI-SIG).

### *controller*

A PCI expansion card.

### *PCI interface*

The whole block of logic that implements the PCI bus.

### *PMC*

PCI Mezzanine Card. A small form factor expansion card based on the PCI specification.

### *agent*

An entity that operates on a computer bus.

### *arbitration boundary*

A point at which bus mastership may be assumed by another master.

### *transaction*

An atomic transfer of one or more bytes on the PCI bus. A transaction defines an arbitration boundary.

### *master*

A master is a PCI module which can initiate a PCI transaction.

### *target*

A PCI target is a module which responds to a PCI transaction.

### *DAC*

Dual Address Cycle. A PCI transaction where a 64-bit address is transferred across a 32-bit data path in two clock cycles.

### *SAC*

Single Address Cycle. A PCI transaction where a 32-bit address is transferred across a 32-bit data path in a single clock cycle.

### *bus device*

General term that refers to either a bus master or target.

### *burst transfer*

The basic bus transfer mechanism of PCI. A burst is comprised of an address phase and one or more data phases.

### *configuration cycle*

Bus cycles used for system initialization and configuration via the configuration address space.

### *Configuration Address Space*

A set of 64 registers (DWORDS) used for configuration, initialization, and catastrophic error handling. This address space consists of two regions: a header region and a device-dependent region.

---

## **PCI bus commands**

Bus commands indicate to a target agent the type of transaction the bus master is requesting. All bus commands are encoded on the Bus command and Byte Enable pins (C/BE[3::0]#) during the address phase. PCI bus command types are as follows:

### *Interrupt Acknowledge*

Acknowledges an interrupt. The Interrupt Acknowledge command is a read that is implicitly addressed to the interrupt controller.

### *Special Cycle*

Simple message broadcast mechanism. Used as an alternative to physical signals when sideband communication is required.

### *I/O Read.*

Reads data from an agent mapped in I/O address space.

### *I/O Write*

Writes data to an agent that is mapped in I/O address space.

### *Reserved*

Reserved for future use.

### *Memory Read*

Reads data from an agent mapped in memory address space.

### *Memory Write*

Writes data to an agent mapped in memory address space.

### *Configuration Read*

Reads the configuration space of an agent.

### *Configuration Write*

Transfers data to the configuration space of an agent.

### *Memory Read Multiple*

Similar to the Memory Read command. Indicates that the master may want to fetch more than one cacheline before disconnecting.

### *Dual Address Cycle*

Transfers a 64-bit address to devices that support 64-bit addressing when the address is not in the low 4 GB address space. Targets that support only 32-bit addressing treat this command as Reserved.

### *Memory Read Line*

Similar to the Memory Read command. Indicates that the master intends to fetch a complete cacheline. It is typically used with bulk sequential data transfers to increase performance.

### *Memory Write and Invalidate*

Similar to the Memory Write command. Guarantees a minimum of one complete cacheline.

---

## **PCI physical characteristics**

PCI defines two expansion card connectors: 5 volt signaling connectors and 3.3 volt signaling connectors. To accommodate both voltages and to provide a smooth migration path between voltages, three electrical types are defined for expansion cards:

- *5 volt boards*, which plug into a 5 volt connector
- *3.3 volt boards*, which plug into 3.3 volt connectors
- *universal boards*, which plug into either 5 volt or 3.3 volt connectors

Additionally, PCI specifies two form factors for expansion cards. One type is known as PMC (PCI Mezzanine Card), based on CMC IEEE P1386. Mezzanine cards have a form factor similar to an SBUS card. The other type is similar to an EISA bus card and is common in most PCs. PCI defines three sizes of these cards:

- long
- short
- variable short length

It is not a requirement for any system to support all three sizes.

Two types of backplates are currently defined: ISA/EISA and Micro-Channel compatible.

## PCI bus signals

The PCI bus requires a minimum of 47 pins for a target-only device and 49 pins for a master to handle data and addressing, interface control, arbitration, and system functions. Table 6 and Table 7 list required and optional signals.

Table 6 PCI bus signals (required pins)

| Functional group           | Signal name | Description                                                                                                                       |
|----------------------------|-------------|-----------------------------------------------------------------------------------------------------------------------------------|
| Address and data           | AD[31::00]  | Address and Data (multiplexed on same pins)                                                                                       |
|                            | C/BE[3::0]# | Bus command (address phase) and Byte Enables (data phase) (multiplexed on same pins)                                              |
|                            | PAR         | Parity (even)—required by all PCI agents                                                                                          |
| Interface control          | FRAME#      | Cycle Frame—used by master to indicate the start and duration of an access                                                        |
|                            | TRDY#       | Initiator Ready—initiating agent is ready to complete current data phase of the transaction                                       |
|                            | IRDY#       | Target Ready—target agent is ready to complete current data phase of the transaction                                              |
|                            | STOP#       | Stop—used by target to request that master stop the current transaction                                                           |
|                            | DEVSEL#     | Device Select—when asserted, indicates driving device has decoded its address as the target of the current access                 |
|                            | IDSEL       | Initialization Device Select—chip select during config and R/W transactions                                                       |
| Error reporting            | PERR#       | Parity Error—used to report data parity errors during PCI transactions (except Special Cycle)                                     |
|                            | SERR#       | System Error—used to report address parity errors, data parity errors on Special Cycle command, and all other catastrophic errors |
| Arbitration (masters only) | REQ#        | Request—request the use of the bus                                                                                                |
|                            | GNT#        | Grant—access to bus is granted                                                                                                    |
| System                     | CLK         | Clock—provides timing for all transactions                                                                                        |
|                            | RST#        | Reset—sets PCI-specific registers, sequencers, and signals to a consistent state                                                  |

**Table 7** PCI bus signals (optional pins)

| Functional group                                                                                           | Signal name | Description                                                                              |
|------------------------------------------------------------------------------------------------------------|-------------|------------------------------------------------------------------------------------------|
| 64-bit extension (optional)                                                                                | AD[63::32]  | Address and Data (multiplexed on same pins)                                              |
|                                                                                                            | C/BE[7::4]# | Bus command (address phase) and Byte Enables (data phase) (multiplexed on same pins)     |
|                                                                                                            | PAR64       | Parity Upper DWORD—even parity that protects AD[63::32] and C/BE[7::4]#                  |
|                                                                                                            | REQ64#      | Request 64-bit Transfer—indicates that the master wishes to transfer data using 64 bits  |
|                                                                                                            | ACK64#      | Acknowledge 64-bit transfer—indicates the target is ready to transfer data using 64 bits |
| Interface control (optional)                                                                               | LOCK#       | Lock—indicates an atomic operation that may require more than one transaction            |
| Interrupts (optional)                                                                                      | INTA#       | Interrupt A—request an interrupt                                                         |
|                                                                                                            | INTB#       | Interrupt B—request an interrupt (only meaningful on a multi-function device)            |
|                                                                                                            | INTC#       | Interrupt C—request an interrupt (only meaningful on a multi-function device)            |
|                                                                                                            | INTD#       | Interrupt D—request an interrupt (only meaningful on a multi-function device)            |
| Cache support (optional)                                                                                   | SBO#        | Snoop Backoff—when asserted, indicates a hit to a modified line                          |
|                                                                                                            | SDONE       | Snoop Done—indicates status of snoop for current access                                  |
| JTAG/Boundary Scan pins. IEEE Standard 1149.1, Test Access Port and Boundary Scan Architecture (optional). | TDI         | Test Data Input                                                                          |
|                                                                                                            | TDO         | Test Output                                                                              |
|                                                                                                            | TCK         | Test Clock                                                                               |
|                                                                                                            | TMS         | Test Mode Select                                                                         |
|                                                                                                            | TRST#       | Test Reset                                                                               |



This section presents an overview of Small Computer Systems Interface (SCSI) concepts and terminology.

---

## SCSI

SCSI is an I/O bus protocol that uses a parallel bus connection between peripherals. The word "small" in the acronym is an inaccurate description of this popular interface. The SCSI interface is highly flexible and lends itself to a wide variety of applications in systems of all sizes.

SCSI protocol is the logical capabilities of the bus itself rather than the physical characteristics of the peripheral devices. The bus is designed to support up to 16 devices, including one or more hosts. Either asynchronous or synchronous transfer modes can be utilized making a great variety of peripheral devices available for use.

---

## SCSI terminology

SCSI interfaces are generally classified using a combination of the following seven attributes:

### *Ultra*

a synchronous transfer rate of 20 MHz (50 nanosecond cycle time)

### *Fast*

a synchronous transfer rate of 10MHz (100 nanosecond cycle time)

### *Slow*

a synchronous transfer rate of 5MHz (200 nanosecond cycle time)

### *Wide*

a 16-bit wide data path

*Narrow*

an 8-bit wide data path

*Single-ended*

a cable/driver configuration intended for cabling devices that are in close physical proximity, such as in the same cabinet

*Differential*

a cable/driver configuration intended for cabling devices between cabinets

The SCSI interface can support the following types of devices:

- Ultra-and-Wide
- Ultra-and-Narrow
- Fast-and-Wide
- Fast-and-Narrow
- Slow-and-Wide
- Slow-and-Narrow

The type of SCSI interface used is dependent on both the controller and the peripheral device's configuration. In addition, all SCSI devices support asynchronous transfers, which always use a narrow data path.

Devices on the SCSI bus are known as either:

*Initiators*

a device, such as a host system that requests another device on the bus to perform a SCSI operation, or

*Targets*

the object of a request, such as a peripheral device

Some devices can function as both an Initiator and a Target, but usually a device is either one or the other.

Devices on the SCSI bus are characterized by:

*SCSI ID*

a unique bus address, ranging from 0 to 15

SCSI IDs 7 - 0 have the highest priority, and devices 15 - 8 the lowest. Within each group the device with the higher numbered ID has highest priority. ID 7 is normally reserved for the host/initiator as it is in the case of the PMC Ultra SCSI.

*Logical Unit*

a physical or virtual peripheral device addressable through a target

## *LUN*

the Logical Unit Number. An encoded three-bit identifier for the logical unit.

The continued logical connection between two devices is identified by a:

## *Nexus*

a relationship or connection between devices that begins with the establishment of an initial connection and ends with the completion of the I/O process

## *IT Nexus*

a Nexus between initiator and target, established with the selection phase

## *ITL Nexus*

a Nexus between initiator, target, and logical unit, established with the Identify message

---

## **SCSI bus phases**

Communication on the SCSI bus can occur only between two devices at any time.

The SCSI architecture includes eight distinct phases:

1. **BUS FREE**

The BUS FREE phase indicates that there is no current I/O process, and that the SCSI bus is available for a connection.

2. **ARBITRATION**

The ARBITRATION phase allows one SCSI device to gain control of the SCSI bus so that it can initiate or resume an I/O process.

3. **SELECTION**

The SELECTION phase allows an initiator to select a target for the purpose of requesting a target function.

4. **RESELECTION**

A target may disconnect, that is the action of releasing control of the SCSI bus and allowing it to go to the BUS FREE Stage, to perform an operation. RESELECTION therefore, is the reacquisition of the SCSI bus to complete the I/O process begun in the initial connection made during a SELECTION PHASE.

### **Information transfer phases**

5. **COMMAND**

6. **DATA**

7. STATUS
8. MESSAGE

The COMMAND, DATA, STATUS, and MESSAGE phases are all grouped together as the information transfer phases. They are used to transfer data or control information via the DATA BUS.

The information transfer phases use one or more request/acknowledge handshakes to control the information transfer. Each request/acknowledge handshake allows the transfer of one byte or halfword of information.

Synchronous data transfer is optional and is only used in data phases if an agreement has been established between the initiator and target. The agreement specifies the request/acknowledge offset and the minimum transfer period.

---

## **SCSI physical characteristics**

The ANSI SCSI-3 draft specification defines the physical characteristics of the SCSI bus (cable) that includes: cables (bus), transceivers, connectors, signals, terminators, and timing. The controller is designed to comply with the SCSI-3 SPI (SCSI Parallel Interface).

The SCSI bus consists of 28 signals, a differential sense signal, multiple termination power signals, and multiple grounds. Table 8 lists these signals. SCSI devices are connected together in a daisy-chain fashion, making the signals common to all devices. Each end of the cable must be terminated with the characteristic impedance of the bus. The PCI Ultra SCSI controller has onboard terminators that terminate its end of the SCSI cable. The opposite end of the SCSI cable must also have an appropriate termination plug attached.

Table 9 lists the PCI Ultra SCSI controller's SCSI cable signals with their pin locations.

**Table 8 SCSI signals**

| Signal Name | Driven By           | Number of Signals | Meaning                                           |
|-------------|---------------------|-------------------|---------------------------------------------------|
| DB0-15      | Initiator or target | 16                | Data bus                                          |
| Parity      | Initiator or target | 2                 | Parity for data bus                               |
| -ATN        | Initiator           | 1                 | Indicate ATTENTION condition to target            |
| -BSY        | Initiator or target | 1                 | Bus in use                                        |
| -ACK        | Initiator           | 1                 | Acknowledge REQ/ACK transfer handshake to target  |
| -REQ        | Target              | 1                 | Request a transfer from initiator                 |
| -SEL        | Initiator or target | 1                 | Indicate target of SELECTION or RESELECTION phase |
| -C/D        | Target              | 1                 | Indicate control or data on bus                   |
| -MSG        | Target              | 1                 | Indicate that a message phase is occurring        |
| -I/O        | Target              | 1                 | Direction control                                 |
| -RST        | Any                 | 1                 | Indicate bus reset condition                      |
| DIFFSENS    | Cable               | 1                 | Differential cable in use                         |

**Table 9 SCSI 68-pin differential cable pinout**

| Pin    | Signal      | Pin    | Signal      |
|--------|-------------|--------|-------------|
| 1..4   | +DB12..DB15 | 35..38 | -DB12..DB15 |
| 5      | DBP1        | 39     | -DBP1       |
| 6      | GND         | 40     | -GND        |
| 7..14  | +DB0..DB7   | 41..48 | -DB0..DB7   |
| 15     | +DBP        | 49     | -DBP        |
| 16     | DIFFSENS0   | 50     | GND         |
| 17     | TERMPWR     | 51     | TERMPWR     |
| 18     | TERMPWR     | 52     | TERMPWR     |
| 19     | RESERVED    | 53     | RESERVED    |
| 20     | +ATN        | 54     | -ATN        |
| 21     | GND         | 55     | GND         |
| 22     | +BSY        | 56     | -BSY        |
| 23     | +ACK        | 57     | -ACK        |
| 24     | +RST        | 58     | -RST        |
| 25     | +MSG        | 59     | -MSG        |
| 26     | +SEL        | 60     | -SEL        |
| 27     | +C/D        | 61     | -C/D        |
| 28     | +REQ        | 62     | -REQ        |
| 29     | +I/O        | 63     | I/O         |
| 30     | GND         | 64     | GND         |
| 31..34 | +DB8..+DB11 | 65..68 | -DB8..-DB11 |

---

## Ultra SCSI

Ultra SCSI (also called Fast-20) is also defined by ANSI. Ultra SCSI has double the performance of Fast SCSI.

An Ultra SCSI device can connect computers to other computers or to peripheral devices such as disk drives, tape drives, or CD-ROM drives.

Ultra SCSI allows up to 15 SCSI or Ultra SCSI devices to be connected to a single port in daisy chain fashion. Each SCSI device must have a unique SCSI ID. You must have Ultra SCSI devices to achieve Ultra SCSI transfer speeds, but the PCI Ultra SCSI controller is backwards compatible with slower SCSI devices.





This appendix lists the SCSI status codes, lists SCSI sense keys, and provides an interpretation of the Additional sense and Qualifier codes contained in SCSI error messages reported by the console.

A typical SCSI error message is shown below. In the error message, the status (CHECK CONDITION) and sense key (RECOVERED ERROR) are interpreted in the message. Table 10 and Table 11 list all possible status and sense key codes respectively.

The Additional sense and Qualifier codes require interpretation. Use both codes to locate the interpretation in Table 12. In the example, the Additional Sense (0x18) and Qualifier (0x01) codes are interpreted as "recovered data with error correction and retries applied."

```
[+6708 72410001 002a9858 0:7] scsi disk: CHECK CONDITION on disk 0:6:5:0
 Read of logical block 509856, count 128
 disk sd45a, block 254920, 65536 bytes
 Valid = 1, Error code = 0x70
 Segment number = 0x00, Filemark = 0, EOM = 0, ILI = 0
 Sense key = 0x1, "RECOVERED ERROR"
 Information = 0x00 0x07 0xc7 0xe4
```

```
[+6709 72410001 002a9a10 0:7] scsi disk: Additional sense length = 0x0a
 Command-specific information = 0x00 0x00 0x00 0x00
 Additional sense = 0x18, Qualifier = 0x01
 Field replaceable unit code = 0xea
 SKSV = 1, C/D = 0, BPV = 0, Bit pointer = 0
 Field pointer = 0x0003
```

**Table 10** SCSI status codes

| <b>Value</b> | <b>Name</b>                  |
|--------------|------------------------------|
| 0x00         | good                         |
| 0x02         | check condition              |
| 0x04         | condition met                |
| 0x08         | busy                         |
| 0x10         | intermediate                 |
| 0x14         | intermediate - condition met |
| 0x18         | reservation conflict         |
| 0x22         | command terminated           |
| 0x28         | queue full                   |

**Table 11** SCSI sense keys

| <b>Value</b> | <b>Name</b>     |
|--------------|-----------------|
| 0            | no sense        |
| 0x1          | recovered error |
| 0x2          | not ready       |
| 0x3          | medium error    |
| 0x4          | hardware error  |
| 0x5          | illegal request |
| 0x6          | unit attention  |
| 0x7          | data protect    |
| 0x8          | blank check     |
| 0x9          | vendor-specific |
| 0xa          | copy aborted    |
| 0xb          | aborted command |
| 0xc          | equal           |
| 0xd          | volume overflow |
| 0xe          | miscompare      |
| 0xf          | reserved        |

**Table 12** SCSI Additional sense and Qualifier codes

| <b>Additional sense</b> | <b>Qualifier</b> | <b>Description</b>                                    |
|-------------------------|------------------|-------------------------------------------------------|
| 0x00                    | 0x00             | no additional sense information                       |
| 0x00                    | 0x01             | filemark detected                                     |
| 0x00                    | 0x02             | end-of-partition/medium detected                      |
| 0x00                    | 0x03             | setmark detected                                      |
| 0x00                    | 0x04             | beginning of partition/medium detected                |
| 0x00                    | 0x05             | end-of-data detected                                  |
| 0x00                    | 0x06             | i/o process terminated                                |
| 0x00                    | 0x11             | audio play operation in progress                      |
| 0x00                    | 0x12             | audio play operation paused                           |
| 0x00                    | 0x13             | audio play operation successfully completed           |
| 0x00                    | 0x14             | audio play operation stopped due to error             |
| 0x00                    | 0x15             | no current audio status to return                     |
| 0x01                    | 0x00             | no index/sector signal                                |
| 0x02                    | 0x00             | no seek complete                                      |
| 0x03                    | 0x00             | peripheral device write fault                         |
| 0x03                    | 0x01             | no write current                                      |
| 0x03                    | 0x02             | excessive write errors                                |
| 0x04                    | 0x00             | logical unit not ready, cause not reportable          |
| 0x04                    | 0x01             | logical unit is in process of becoming ready          |
| 0x04                    | 0x02             | logical unit not ready, initializing command required |
| 0x04                    | 0x03             | logical unit not ready, manual intervention required  |
| 0x04                    | 0x04             | logical unit not ready, format in progress            |

**Table 12 SCSI Additional sense and Qualifier codes (continued)**

| <b>Additional sense</b> | <b>Qualifier</b> | <b>Description</b>                              |
|-------------------------|------------------|-------------------------------------------------|
| 0x05                    | 0x00             | logical unit does not respond to selection      |
| 0x06                    | 0x00             | reference position found                        |
| 0x07                    | 0x00             | multiple peripheral devices selected            |
| 0x08                    | 0x00             | logical unit communication failure              |
| 0x08                    | 0x01             | logical unit communication time-out             |
| 0x08                    | 0x02             | logical unit communication parity error         |
| 0x09                    | 0x00             | track following error                           |
| 0x09                    | 0x01             | tracking servo failure                          |
| 0x09                    | 0x02             | focus servo failure                             |
| 0x09                    | 0x03             | spindle servo failure                           |
| 0x0a                    | 0x00             | error log overflow                              |
| 0x0c                    | 0x00             | write error                                     |
| 0x0c                    | 0x01             | write error recovered with auto reallocation    |
| 0x0c                    | 0x02             | write error - auto reallocation failed          |
| 0x10                    | 0x00             | id crc or ecc error                             |
| 0x11                    | 0x00             | unrecovered read error                          |
| 0x11                    | 0x01             | read retries exhausted                          |
| 0x11                    | 0x02             | error too long to correct                       |
| 0x11                    | 0x03             | multiple read errors                            |
| 0x11                    | 0x04             | unrecovered read error - auto reallocate failed |
| 0x11                    | 0x05             | l-ec uncorrectable error                        |
| 0x11                    | 0x06             | circ unrecovered error                          |
| 0x11                    | 0x07             | data resynchronization error                    |
| 0x11                    | 0x08             | incomplete block read                           |
| 0x11                    | 0x09             | no gap found                                    |
| 0x11                    | 0x0a             | miscorrected error                              |

**Table 12 SCSI Additional sense and Qualifier codes (continued)**

| <b>Additional sense</b> | <b>Qualifier</b> | <b>Description</b>                                  |
|-------------------------|------------------|-----------------------------------------------------|
| 0x11                    | 0x0b             | unrecovered read error - recommend reassignment     |
| 0x11                    | 0x0c             | unrecovered read error - recommend rewrite the data |
| 0x12                    | 0x00             | address mark not found for id field                 |
| 0x13                    | 0x00             | address mark not found for data field               |
| 0x14                    | 0x00             | recorded entity not found                           |
| 0x14                    | 0x01             | record not found                                    |
| 0x14                    | 0x02             | filemark or setmark not found                       |
| 0x14                    | 0x03             | end-of-data not found                               |
| 0x14                    | 0x04             | block sequence error                                |
| 0x15                    | 0x00             | random positioning error                            |
| 0x15                    | 0x01             | mechanical positioning error                        |
| 0x15                    | 0x02             | positioning error detected by read of medium        |
| 0x16                    | 0x00             | data synchronization mark error                     |
| 0x17                    | 0x00             | recovered data with no error correction applied     |
| 0x17                    | 0x01             | recovered data with retries                         |
| 0x17                    | 0x02             | recovered data with positive head offset            |
| 0x17                    | 0x03             | recovered data with negative head offset            |
| 0x17                    | 0x04             | recovered data with retries and/or circ applied     |
| 0x17                    | 0x05             | recovered data using previous sector id             |
| 0x17                    | 0x06             | recovered data without ecc - data auto-reallocated  |
| 0x17                    | 0x07             | recovered data without ecc - recommend reassignment |

**Table 12 SCSI Additional sense and Qualifier codes (continued)**

| <b>Additional sense</b> | <b>Qualifier</b> | <b>Description</b>                                       |
|-------------------------|------------------|----------------------------------------------------------|
| 0x17                    | 0x08             | recovered data without ecc - recommend rewrite           |
| 0x18                    | 0x00             | recovered data with error correction applied             |
| 0x18                    | 0x01             | recovered data with error correction and retries applied |
| 0x18                    | 0x02             | recovered data - data auto-reallocated                   |
| 0x18                    | 0x03             | recovered data with circ                                 |
| 0x18                    | 0x04             | recovered data with lec                                  |
| 0x18                    | 0x05             | recovered data - recommend reassignment                  |
| 0x18                    | 0x06             | recovered data - recommend rewrite                       |
| 0x19                    | 0x00             | defect list error                                        |
| 0x19                    | 0x01             | defect list not available                                |
| 0x19                    | 0x02             | defect list error in primary list                        |
| 0x19                    | 0x03             | defect list error in grown list                          |
| 0x1a                    | 0x00             | parameter list length error                              |
| 0x1b                    | 0x00             | synchronous data transfer error                          |
| 0x1c                    | 0x00             | defect list not found                                    |
| 0x1c                    | 0x01             | primary defect list not found                            |
| 0x1c                    | 0x02             | grown defect list not found                              |
| 0x1d                    | 0x00             | miscompare during verify operation                       |
| 0x1e                    | 0x00             | recovered id with ecc                                    |
| 0x20                    | 0x00             | invalid command operation code                           |
| 0x21                    | 0x00             | logical block address out of range                       |
| 0x21                    | 0x01             | invalid element address                                  |
| 0x22                    | 0x00             | illegal function                                         |
| 0x24                    | 0x00             | invalid field in cdb                                     |
| 0x25                    | 0x00             | logical unit not supported                               |
| 0x26                    | 0x00             | invalid field in parameter list                          |

**Table 12 SCSI Additional sense and Qualifier codes (continued)**

| <b>Additional sense</b> | <b>Qualifier</b> | <b>Description</b>                                      |
|-------------------------|------------------|---------------------------------------------------------|
| 0x26                    | 0x01             | parameter not supported                                 |
| 0x26                    | 0x02             | parameter value invalid                                 |
| 0x26                    | 0x03             | threshold parameters not supported                      |
| 0x27                    | 0x00             | write protected                                         |
| 0x28                    | 0x00             | not ready to ready transition (medium may have changed) |
| 0x28                    | 0x01             | import or export element accessed                       |
| 0x29                    | 0x00             | power on, reset, or bus device reset occurred           |
| 0x2a                    | 0x00             | parameters changed                                      |
| 0x2a                    | 0x01             | mode parameters changed                                 |
| 0x2a                    | 0x02             | log parameters changed                                  |
| 0x2b                    | 0x00             | copy cannot execute since host cannot disconnect        |
| 0x2c                    | 0x00             | command sequence error                                  |
| 0x2c                    | 0x01             | too many windows specified                              |
| 0x2f                    | 0x00             | commands cleared by another initiator                   |
| 0x30                    | 0x00             | incompatible medium installed                           |
| 0x30                    | 0x01             | cannot read medium - unknown format                     |
| 0x30                    | 0x02             | cannot read medium - incompatible format                |
| 0x30                    | 0x03             | cleaning cartridge installed                            |
| 0x31                    | 0x00             | medium format corrupted                                 |
| 0x32                    | 0x00             | no defect spare location available                      |
| 0x32                    | 0x01             | defect list update failure                              |
| 0x33                    | 0x00             | tape length error                                       |
| 0x36                    | 0x00             | ribbon, ink, or tower failure                           |
| 0x37                    | 0x00             | rounded parameter                                       |
| 0x39                    | 0x00             | saving parameters not supported                         |

**Table 12 SCSI Additional sense and Qualifier codes (continued)**

| <b>Additional sense</b> | <b>Qualifier</b> | <b>Description</b>                               |
|-------------------------|------------------|--------------------------------------------------|
| 0x3a                    | 0x00             | medium not present                               |
| 0x3b                    | 0x00             | sequential positioning error                     |
| 0x3b                    | 0x01             | tape position error at beginning-of-medium       |
| 0x3b                    | 0x02             | tape position error at end-of-medium             |
| 0x3b                    | 0x03             | tape or electronic vertical forms unit not ready |
| 0x3b                    | 0x04             | slew failure                                     |
| 0x3b                    | 0x05             | paper jam                                        |
| 0x3b                    | 0x06             | failed to sense top-of-form                      |
| 0x3b                    | 0x07             | failed to sense bottom-of-form                   |
| 0x3b                    | 0x08             | reposition error                                 |
| 0x3b                    | 0x09             | read past end of medium                          |
| 0x3b                    | 0x0a             | read past beginning of medium                    |
| 0x3b                    | 0x0b             | position past end of medium                      |
| 0x3b                    | 0x0c             | position past beginning of medium                |
| 0x3b                    | 0x0d             | medium destination element full                  |
| 0x3b                    | 0x0e             | medium source element empty                      |
| 0x3d                    | 0x00             | invalid bits in identify message                 |
| 0x3e                    | 0x00             | logical unit has not self-configured yet         |
| 0x3f                    | 0x00             | target operating conditions have changed         |
| 0x3f                    | 0x01             | microcode has been changed                       |
| 0x3f                    | 0x02             | changed operating definition                     |
| 0x3f                    | 0x03             | inquiry data has changed                         |
| 0x40                    | 0x00             | ram failure                                      |
| 0x40                    | nn               | diagnostic failure on component nn               |
| 0x41                    | 0x00             | data path failure                                |
| 0x42                    | 0x00             | power-on or self-test failure                    |
| 0x43                    | 0x00             | message error                                    |

**Table 12 SCSI Additional sense and Qualifier codes (continued)**

| <b>Additional sense</b> | <b>Qualifier</b> | <b>Description</b>                                   |
|-------------------------|------------------|------------------------------------------------------|
| 0x44                    | 0x00             | internal target failure                              |
| 0x45                    | 0x00             | select or reselect failure                           |
| 0x46                    | 0x00             | unsuccessful soft reset                              |
| 0x47                    | 0x00             | scsi parity error                                    |
| 0x48                    | 0x00             | initiator detected error message received            |
| 0x49                    | 0x00             | invalid message error                                |
| 0x4a                    | 0x00             | command phase error                                  |
| 0x4b                    | 0x00             | data phase error                                     |
| 0x4c                    | 0x00             | logical unit failed self-configuration               |
| 0x4e                    | 0x00             | overlapped commands attempted                        |
| 0x50                    | 0x00             | write append error                                   |
| 0x50                    | 0x01             | write append position error                          |
| 0x50                    | 0x02             | position error related to timing                     |
| 0x51                    | 0x00             | erase failure                                        |
| 0x52                    | 0x00             | cartridge fault                                      |
| 0x53                    | 0x00             | media load or eject failed                           |
| 0x53                    | 0x00             | unload tape failure                                  |
| 0x53                    | 0x00             | medium removal prevented                             |
| 0x53                    | 0x00             | scsi to host system interface failure                |
| 0x53                    | 0x00             | system resource failure                              |
| 0x53                    | 0x00             | unable to recover table-of-contents                  |
| 0x53                    | 0x00             | generation does not exist                            |
| 0x53                    | 0x00             | updated block read                                   |
| 0x53                    | 0x00             | operator request or state change input (unspecified) |
| 0x53                    | 0x00             | operator medium removal request                      |
| 0x53                    | 0x00             | operator selected write protect                      |
| 0x53                    | 0x00             | operator selected write permit                       |

**Table 12** SCSI Additional sense and Qualifier codes (continued)

| <b>Additional sense</b> | <b>Qualifier</b> | <b>Description</b>                         |
|-------------------------|------------------|--------------------------------------------|
| 0x53                    | 0x00             | log exception                              |
| 0x53                    | 0x00             | threshold condition met                    |
| 0x53                    | 0x00             | log counter at maximum                     |
| 0x53                    | 0x00             | log list codes exhausted                   |
| 0x53                    | 0x00             | rpl status change                          |
| 0x53                    | 0x00             | spindles synchronized                      |
| 0x53                    | 0x00             | spindles not synchronized                  |
| 0x53                    | 0x00             | lamp failure                               |
| 0x53                    | 0x00             | video acquisition error                    |
| 0x53                    | 0x00             | unable to acquire video                    |
| 0x53                    | 0x00             | out of focus                               |
| 0x53                    | 0x00             | scan head positioning error                |
| 0x53                    | 0x00             | end of user area encountered on this track |
| 0x53                    | 0x00             | illegal mode for this track                |



---

# Index

---

## A

about firmware command 33  
Additional sense and Qualifier codes 58  
ANSI SCSI-3 draft specification 50  
ANSI X3.131-1994 SCSI-2 standard 1  
ANSI X3T10/1071D SCSI-3 Fast-20 standard 1  
antistatic packaging 7, 19  
asynchronous transfer mode 1

---

## C

cables  
connecting SCSI cables 17, 18  
SCSI differential 3  
SCSI ribbon 2, 3  
unplugging EIOB power cable 8, 13, 20, 25  
cautions  
handling circuit boards 7, 19  
overwriting original firmware 36  
removing EIOB 9, 21  
Class 12 - Utility Functions 38  
Class 3 - EPIC PCI Access Test 32, 34  
Class 4 - QLogic Mailbox Test 32, 34  
commands  
about firmware 33  
cxtest 32, 33, 34  
fwcp (OPB) 36  
load ram mailbox 33  
PCI Local Bus 42  
verify checksum mailbox 33  
connections, checking 31  
Control and Status Registers 32  
core logic flash 36  
CSRs 32, 33  
cxtest command 32, 33, 34, 38

---

## D

damage claim form 5  
damage claims 5  
data parity errors 44  
diagnostics 31  
Class 4 QLogic Mailbox Test 33  
400 QLogic Mailbox Test 33  
405 QLogic Firmware Download and Test 33  
classes 32  
cxtest command 33

---

EPIC Configuration Space Test 32  
EPIC I/O and Memory Space Test 32  
EPIC PCI Access Test 32  
io3000 32, 34  
overview 32  
parameters  
Controller 35  
EPIC 35  
Logical Unit Number 35  
Target device number 35  
QLogic Firmware Download and Test 33  
QLogic Mailbox Test 32, 33  
running SCSI 34  
subtests 32, 34  
utility functions 38  
differential 48  
cable pinout 52  
mode 2

---

## E

EIOB  
caution in removing 9  
locations 10, 22  
reinstalling 16, 28  
removing 9, 14, 21, 26  
unplugging power cable 8, 13, 20, 25  
electrostatic discharge 7  
EMI panels 18  
removing 12, 24  
ENRB 14, 26  
EPIC 32  
EPIC Configuration Space Test 32  
EPIC I/O and Memory Space Test 32  
EPIC PCI Access Test 32  
300 EPIC Configuration Space Test 32  
305 EPIC I/O and Memory Space Test 32  
Exemplar  
Exemplar Node Routing Board (ENRB) 14, 26  
Exemplar PCI Interface Chip (EPIC) 32

---

## F

fast SCSI 47  
FCC notice xi  
firmware  
overwriting original 36  
SCSI 33, 37  
Ultra SCSI runtime 36

---

upgrading, instructions 36  
forth code, upgrading 37  
fwcp command (OBP) 36

---

## H

Hewlett-Packard Convex Technical Assistance Center  
(TAC) xi

---

## I

I/O Base Address Register 32  
I/O cycles 32  
information transfer phases 49  
initiators 48  
inspection 5  
installation procedures 7  
    completing 18  
    ESD precautions 7  
    overview 8  
    preinstallation requirements 8  
    preparation 7  
    summary 8  
io3000 34  
io3000 Class Menu dialog 34  
IOLF 13, 25  
IOLR 13, 25  
IORF 13, 25  
IORR 13, 25  
IT nexus 49  
ITL nexus 49

---

## K

keyswitch 18

---

## L

load ram mailbox command 33  
logical unit 48  
Logical Unit Number (LUN) 2, 49

---

## M

Memory Base Address Register 32  
memory cycle 32

---

## N

narrow SCSI 48  
nexus 49  
    IT nexus 49  
    ITL nexus 49

---

## O

OBP 34  
    fwcp command 36  
operating temperature 2  
operator panel 18

---

## P

packaging, antistatic 7, 19  
parameters  
    Controller 35  
    EPIC 35  
    Logical Unit Number 35  
    Target device number 35  
parity errors 44  
PCI card cage 15, 27  
    removing bracket 8  
PCI config space cycles 32  
PCI Interface Chip 32  
PCI Local Bus 39  
    commands 42  
    description 40  
    physical characteristics 43  
    signals 44  
    Specification 1, 39  
    terminology 41  
PCI slot numbering 35  
PCI Special Interest Group, address 39  
PCI Ultra SCSI controller  
    compliance features 1  
    connecting to external device 8  
    description 1  
    diagnostics 32  
    electrostatic discharge 7  
    Field Replacement Units 31, 38  
    inspecting 5  
    installing 7  
    operating with nonreleased firmware 37  
    PCI Interface Chip 32  
    preinstallation requirements 8  
    removal 19  
    running diagnostics 31  
    specifications 2  
    troubleshooting 31  
    unpacking 5

---

checklist 5  
Power On Self Test (POST) messages 8  
power, shutting down 9, 21

---

## Q

QLogic Firmware Download and Test 33  
QLogic Mailbox Test 32, 33  
Qualifier codes 58

---

## R

reinstalling, EIOB 16, 28  
removal procedures 19  
    completing 29  
    ESD precautions 19  
    summary 20  
removing  
    EIOB 9, 14, 21, 26  
    EMI panel 12, 24  
    PCI card cage 8  
    side skins 11, 23  
reselection 49  
runtime firmware 36

---

## S

SCSI 47  
    Additional sense and Qualifier codes 58  
    bus signals 50  
    cables 3  
    devices 48  
    error messages 55  
    firmware 33, 37  
    ID 15, 48  
    overview 47  
    physical characteristics 50  
    ribbon cables 2, 3  
    running diagnostics 34  
    sense codes 31, 55  
    sense keys 57  
    signals 51  
    status codes 55, 56  
    terminators 15  
    terminology 47  
    ultra 53  
SCSI bus phases  
    arbitration 49  
    bus free 49  
    command 49  
    data 49  
    information transfer phases 49  
    message 50

    reselection 49  
    selection 49  
    status 50  
SCSI terminology 47  
    differential 48  
    fast 47  
    initiators 48  
    logical unit 48  
    LUN 49  
    narrow 48  
    nexus 49  
    single-ended 48  
    slow 47  
    targets 48  
    wide 48  
selection 49  
sense code 55  
sense keys, SCSI 57  
shutdown 9, 21  
side skins, removing 11, 23  
signals, PCI Local Bus 44  
single-ended 48  
slow SCSI 47  
Small Computer Systems Interface (SCSI) 47  
status codes 56  
storage temperature 2  
subtests 34  
synchronous transfer mode 1

---

## T

targets 48  
Technical Assistance Center (TAC) xi, 32  
temperature  
    operating 2  
    storage 2  
terminators 15, 50  
Test Controller 34  
    standalone mode 32  
test station 34, 36, 37  
transfer modes  
    asynchronous 1  
    synchronous 1  
troubleshooting 31

---

## U

ultra SCSI 1, 2, 47, 53  
    transfer speeds 53  
unpacking 5  
    checklist 5  
upgrading firmware 36

---

---

## V

verify checksum mailbox command 33

---

## W

Wide and Fast SCSI 2  
wide SCSI 47



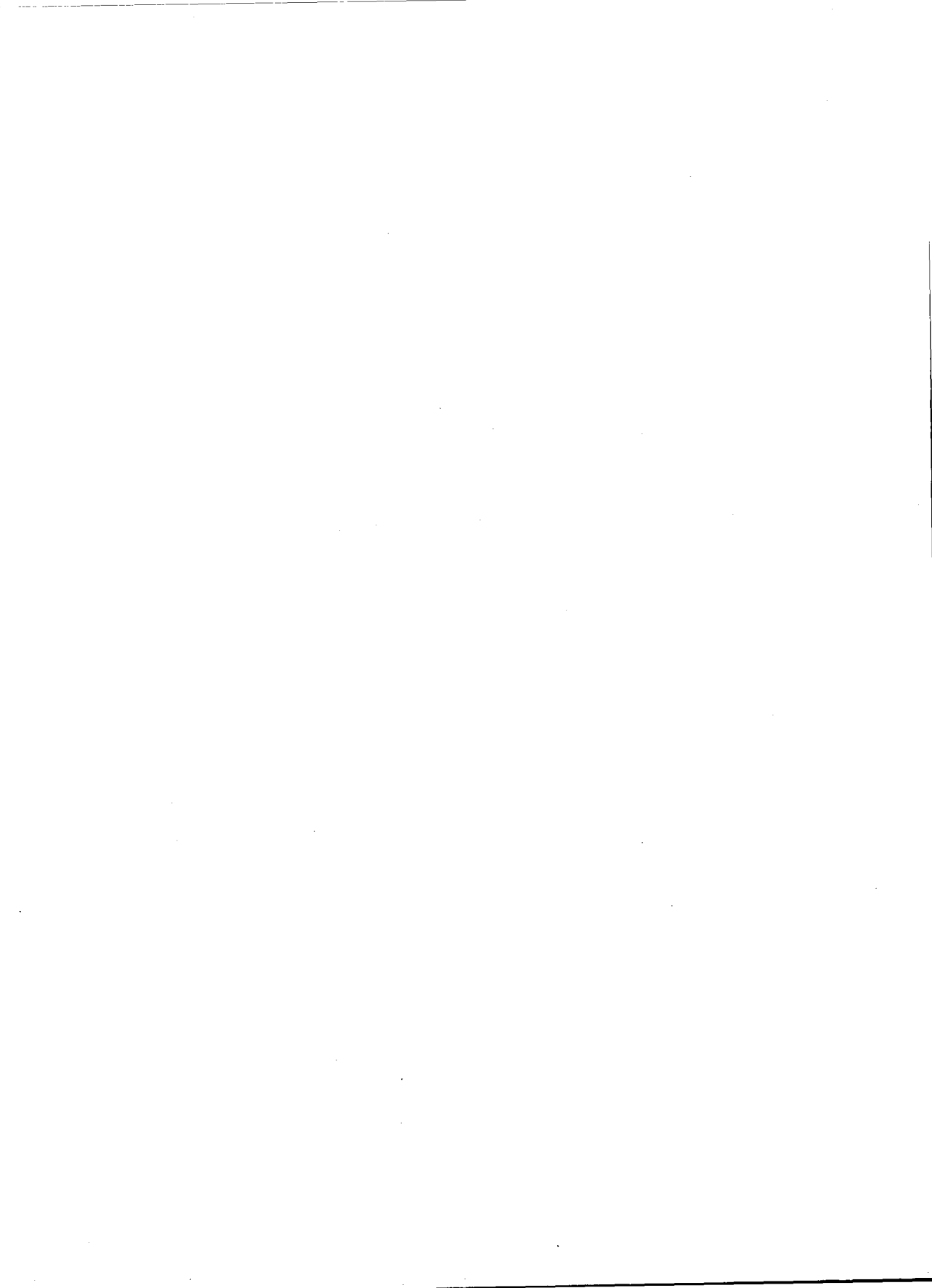





CONVEX  
PRESS

A4716-90024

